



2014

# A Quick Introduction to Debating in Schools

WSDC Format and  
Club or Classroom Implementation



**Christopher Sanchez**  
Debating Society Germany e.V.  
Max-Born-Gymnasium, Backnang  
August 2012-2014  
[www.schoolsdebate.de](http://www.schoolsdebate.de)

## Table of contents

Dear educator	3
An introduction to debating	5
1 The World Schools Debate Format (WSDC)	6
1.1 What to debate about: the motions	6
1.2 Prepared and impromptu debates	7
1.3 Course of the debate and timing	8
1.3.1 Proposition and Opposition	8
1.3.2 Duration and succession of speeches	8
1.3.3 Points of Information (POIs)	9
1.4 The cast involved in debating	10
1.4.1 The debaters	10
1.4.2 Chairperson and timekeeper	10
1.4.3 The judges	11
1.4.4 The coach	11
1.4.5 The audience	12
1.4.6 The tabber	12
1.5 Speaker roles	13
1.5.1 First PROP	13
1.5.2 First OPP	14
1.5.3 Second PROP	16
1.5.4 Second OPP	16
1.5.5 Third PROP	16
1.5.6 Third OPP	16
1.5.7 OPP and PROP reply speeches	16
1.6 Viewing a debate online	17
1.7 Judging	18
1.7.1 The marking standard	18
1.7.2 Judging <i>Style</i>	20
1.7.3 Judging <i>Content</i>	20
1.7.4 Judging <i>Strategy</i>	21
1.7.5 Filling in the mark sheet	22
2 Debate club implementation	24
2.1 Acquiring debaters for a club	24
2.1.1 Bottom-up or top-down?	24
2.1.2 School and university student instructors	25
2.2 Debate club curricula	25
2.2.1 Beginners (year 7)	26

2.2.2 Juniors (years 8 and 9)	27
2.2.3 Seniors (> year 10)	28
2.3 Debating games and exercises	29
2.3.1 Games for Content	29
2.3.2 Games for Style	32
2.3.3 Games for Strategy	33
2.3.4 Other activities to shape the debater's mind	33
2.3.5 Multi-Argument development exercise	36
2.3.6 Four-step refutation exercise	36
2.3.7 Public speaking exercise	37
2.3.8 Definition attack exercise	37
2.4 Preparing a debate	38
2.4.1 Areas of argumentation (SPERM model)	38
2.4.2 Argument structure (ARE/SEE models)	39
2.4.3 The case	40
2.4.4 Avoiding fallacies	42
2.4.5 Preparing impromptu debates	43
2.5 Model debates	44
2.5.1 Balloon debate	44
2.5.2 Fun Debate	44
2.5.3 WSDC Mini-debates	44
2.6 Creating reply speeches	45
3 Debating in the classroom	46
3.1 Debate topic selection	46
3.2 45-minute lessons	46
3.2.1 Group activities	47
3.2.2 Group debates	47
3.3 90-minute lessons	48
4 Debating tournaments in Germany	50
4.1 DSG Junior League (JL)	50
4.2 DSG Senior League (SL)	51
4.3 German Schools Debating Championship (GSDC)	51
4.4 EurOpen	52
4.5 University Debating	52
5. Debating tournaments abroad	53
Teaching sheets / Appendix (i-xvii)	54



[www.schoolsdebate.de](http://www.schoolsdebate.de)

## Dear educator

Judging by the size this manual has turned out to be, I must admit that I would have probably made a very poor debater. Try as I might, I was not able to keep this handbook 'short', in order for you to have a genuinely 'quick' introduction to debating in schools. As it turns out, debating simply has too large an array of skills involved, as well as rules and regulations that need to be kept to, for it to be put into only, say, ten pages. This is one of the main reasons why debating is a powerfully educational tool.

This manual is an attempt at putting a step-by-step introduction into the hands of teachers or other people in connection with pupils, who have the capacity of offering them debating as a truly amazing component to their foreign language acquisition, without having any knowledge on the matter whatsoever. As it is the case with many other unfamiliar things, becoming acquainted with the full spectrum of debating may take some time and unavoidably some extensive reading.

This compendium is aimed at guiding you through the process of getting a very general idea of what is happening in schools debating in Germany in particular, but can be used in other countries as well, of course. Even though I will be talking about the **World Schools Debating Championship (WSDC)** a lot, this manual doesn't prepare you for this "Olympics of debating", but should offer you a kind of kick-start into implementing it at your school as either a club or simply as an element in your English class.

The connection with WSDC, however, cannot be ignored, since we, the Stuttgart-based **Debating Society Germany e.V. (DSG)** have designed all activities and tournaments in accordance with the WSDC format, the highest authority in schools debating at this time. The rules and regulations are quite complex for beginners, and I won't be able to refrain from adding cross-references to them, but what I'm trying to achieve generally is to give you and your debaters something easily digestible to start off with.

Despite teachers' efforts to increase speaking time in class, the time spent speaking in debating is significantly higher. Pupils talk extensively about issues they're interested in, are listened to and also taken seriously by other peers. The means of implementing debate into classrooms is part of the goal of this tutorial.

There are many more advantages that can be attributed to debating, like losing the fear of speaking in front of an audience and in a foreign language, as well as improving presentation skills, doing research on globally important issues, using logical analysis, creating depth to argumentation, experiencing teamwork, developing various orator skills and eventually intercultural experience.

Unavoidably, debaters will also learn to cope with defeat.

Pupils must understand, however, that their language skills are not under scrutiny. Even at WSDC, it is absolutely prohibited to mark students down for their quality of English.

For most of the students, debating becomes more than just an activity, but a kind of hobby, meeting at league rounds on Saturdays, spending time at home doing research and gradually see their own diction, pronunciation, communicative skills and other useful capacities in preparation for their work

life improve significantly. Weekends spent in hostels for multi-day tournament meetings and *friendly debates* add an additional social incentive to the activity.

You may have your very own reasons why you want to install or expand debating at your school and I really hope you find this reference manual full of texts, diagrams and links to a plethora of internet resources helpful, through which you will be able to watch debates and also watch feedback to those debates in order to get a clear picture of what will be expected from your debaters and what debaters will expect from you and from us as the DSG.

Happy reading and debating! Really hoping to see you soon!



Christopher Sanchez  
Max-Born-Gymnasium, Backnang  
Chairman, Debating Society Germany e.V.  
August 2012

Many thanks go to:

- **Samuel Myat San** from Singapore for letting me make references to his marvelous website full of WSDC debating resources [www.debateable.org](http://www.debateable.org)
- **Dr. Alfred 'Tuna' Snider** from the University of Vermont for letting me use his workshop materials and for uploading numerous films on debating.
- **QatarDebate**, a member of the **Qatar Foundation** for creating priceless educational material on film and for sharing it with the whole world online.
- **Carmen Belafi** from the University of Tübingen and soon UCT Cape Town for commenting on the progress of this manual. As a former national debater, she is probably a higher authority on the matter than I am.
- **Jana Gilke** from the University of Mannheim and co-chairperson of DSG for proofreading the script. She has also experienced much more in debating than me, including coaching the national team.
- **David Whitehead**, former chairman of the DSG, for giving the manual some last native-tongue language tweaking

## An introduction to debating

A debate is an exchange of arguments between two teams or individuals. Meetings take place on regional, national and international levels worldwide, mostly in educational environments such as schools and universities. The idea behind the whole discipline of debating is to teach or to perform the approach to a certain topic from different points of view. The side one has to debate on is drawn by tournament organisers, so personal opinions are secondary.

If a debater, for instance, is against the death penalty but has to defend it in a debate, the speaker is forced to find out which arguments could actually be used in favour of it. The basis of academic discourse lies in the assessment of both sides to a topic before shaping an opinion. One can still be against the death penalty after successfully having defended it in a debate. However, the educational goal is to be able to understand the motivation of people who may think otherwise while still respecting their different views.

A team's success in a debate is determined by impartial judges. They evaluate the selection, quality and arrangement of arguments used and assess the originality and style of the speaker. It is important to know that rules and regulations, such as speaking order and speaking time provide a framework, in which debaters have to conduct their speeches. One cannot simply cut into someone's speech or speak for as long as one likes. There are time limits given, as well as regulations concerning etiquette and sometimes even attire. Debating is designed to be, whereas somewhat aggressive in nature, a platform for mutual respect and understanding.

There are mainly two approaches to getting children acquainted with debating. This handbook mainly aims at introducing debating as a school club, which will be discussed in chapter two.

If you are only interested in classroom debating, chapter three will show a few ideas on its implementation. Games and practices from chapter two will be referred to from there as well.

If you are more inclined to watch an introductory video, this link may be for you. For the sake of brevity, speaking time has been reduced to five minutes (instead of eight). I do suggest, however, that you do some reading at least up to page 18 of this manual if you have absolutely no previous knowledge.

**Please note** that PROP and OPP are seated on the **wrong sides in this video!** PROP should always be (and always is) seated on the left-hand side of the audience.

 [QatarDebate An introduction to Debating](#) on the DSG server(1:01:29)



Pic.1: Group photo of WSDC 2012 participants in Cape Town, South Africa, 48 nations attending

# 1 The World Schools Debate Format (WSDC)

Compared to other debating styles used in schools and universities worldwide, the WSDC (*World Schools Debating Championship*) format features a minimum of three speakers per team. Whereas team size varies between tournaments (usually 3-7), it is only three speakers per team who actually take the floor in a debate, but more speakers per team permit students to switch debate rounds at multi-day tournaments.

Other commonly used debating formats are:

- British Parliamentary ("BP", mostly used in the UK and in universities worldwide)
- Karl-Popper Format ("KP", widespread in Central and Eastern Europe)
- Lincoln-Douglas (used in the USA)

## 1.1 What to debate about: the motions

The given topic that is to be debated about is known as the *motion* or the *resolution*. It usually starts with THBT ("This house believes that...") and then features the proposed change in the status quo. Other abbreviations are THW ("This house would...") or simply TH ("This house..."). The "house" refers to the British parliament's chamber to which the English-born discipline of debating can be traced back in origin, but is transformed into any other setting currently needed for any debate.

Motions are designed by tournament *motion committees* or by the event organisers. Here are some motion examples:

- THBT public transport should be free of charge
- THBT smoking in public places should be banned
- THBT we should abandon nuclear energy
- THW lower the voting age
- THW ban beauty contests
- THW offer dictators immunity in return for giving up power
- TH condemns the influence of the music industry on today's youth

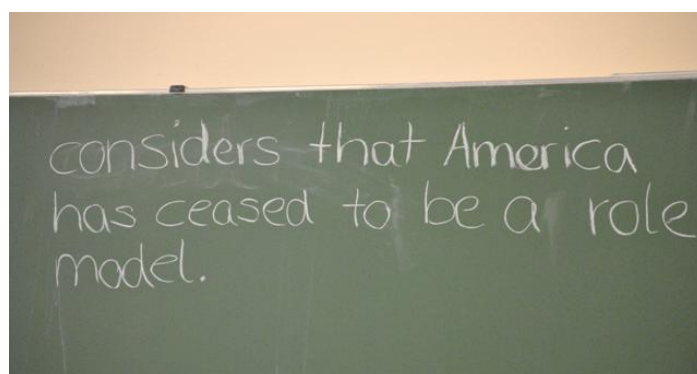

Pic.2: A motion on display

More on motions

<http://debateable.org/debate-topics/motions>

→ Also see Appendix: Motions (xii)



## 1.2 Prepared and impromptu debates

In *prepared debates*, the motions are announced to tournament participants anywhere between a few weeks and a couple of months in advance. Teams have time to research the certain aspects of the motion diligently and prepare their speeches.

In *impromptu debates*, contesting teams receive the motion one hour ahead of the debate. Here, the skill is to rely on one's own general knowledge. However, the teams are allowed three books in the preparation room and also in the debate:

- a bilingual dictionary,
- an English Language (monolingual) dictionary
- a single-volume reference book (encyclopedia, almanac, quotation dictionary...)

There can be a maximum of five team members in the preparation room. The following items are prohibited in the preparation room:

- other handwritten, printed or published materials apart from the ones mentioned above
- mobile phones, particularly smart phones
- cameras
- tablet PCs
- MP3 players
- anything that can store data electronically and/or connect to the internet (...)

These devices must be handed in to the coach ahead of the one-hour *preparation time*.

When designing the motions, tournament organisers pay great attention to whether a motion is acceptable for impromptu debates or not. In the example of "THW support military intervention in Somalia", most people would agree that this is something that takes a great deal of preparation and research, since detailed knowledge about the political and military situation in Somalia cannot be expected from school students, or from any other averagely educated person for that matter, whereas "THW allow free distribution of music on the internet" does not require much previous research and aims more at debating the principle of a certain issue.



Pic.3: Scene from EurOpen 2011 Debating Championship, Stuttgart



## 1.3 Course of the debate and timing

### 1.3.1 Proposition and Opposition

The team known as the *proposition* (PROP), or *government* or *affirmative*, will propose a change in the status quo, whereas the *opposition* (OPP), or *negative*, is defending it. If side PROP wants to win the debate, it generally has to deliver the *burden of proof* on which grounds and according to which line of argumentation (the so-called *case* or *model*) this change should take place, including giving reasons and examples for each of these particular arguments.

It is the OPP's task to *rebut* and *refute* the arguments given by side PROP and to defend the status quo by explaining why a) side PROP's arguments don't stand and b) why things are good the way they are. This constitutes the OPP's *case* or *model*.

Side OPP can choose to, but doesn't have to, create an additional alternative solution to the proposed change of the status quo but mustn't forget to *clash* what has been said by side PROP. Failing to clash the proposing side and to destroy its case is failing the main task side OPP has to fulfill. If there is no, or too little, clash of what has actually been proposed, OPP is likely to lose the debate, even if their *counter-case* may appear more reasonable to some judges.

Teams cannot choose which side to debate on. This is determined by the tournament *draw*. The idea behind this is to teach debaters that there are two sides to every issue, even if you don't support either of them personally.

### 1.3.2 Duration and succession of speeches

Teams perform by delivering three *substantive speeches* (orange, blue and green lines) of eight minutes each and one *reply* or *summary speech* (purple lines), given by either first or second speaker, of four minutes per team, adding up to eight speeches per debate.

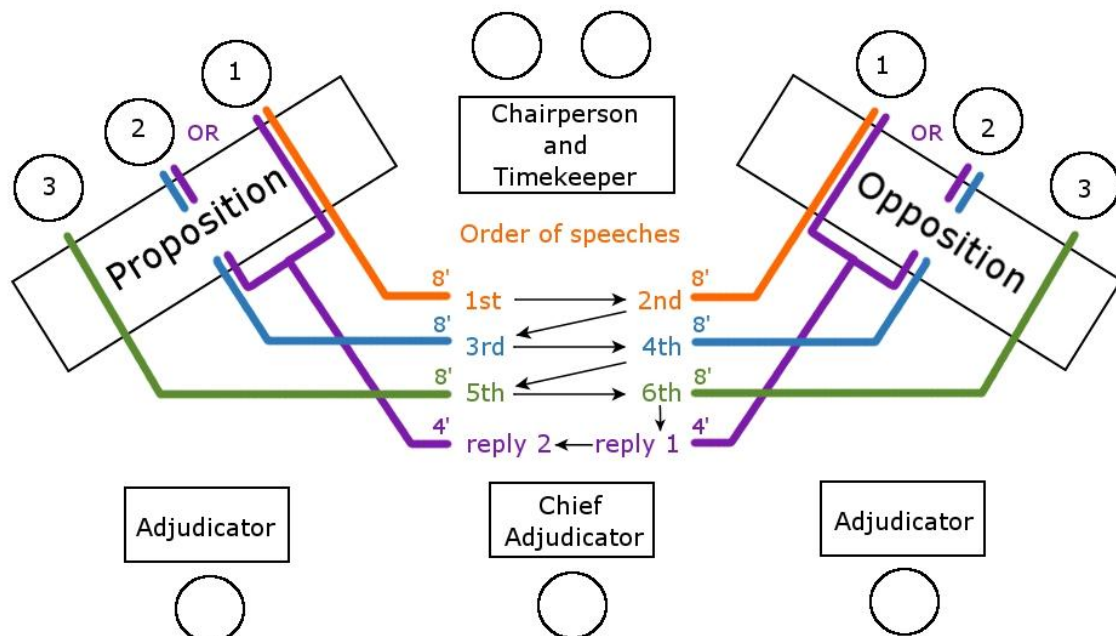

Fig.1: The debate layout

Generally speaking, PROP begins with its first speaker and then the teams take turns, except for the last two speeches, the teams' *reply* or *summary speeches*. After giving the third speech of the opposition (sixth speech of the debate), it's OPP's turn again to deliver its reply speech right after. Side PROP closes the debate with its final reply speech.

### 1.3.3 Points of Information (POIs)

A vital contribution to the debate is the exchange of Points of Information. During the eight-minute *substantive speeches*, and only between minutes 2 and 7 (one minute into the speech and one minute before it ends), team members of the team not currently speaking have the opportunity, even the obligation, to ask a short question or make a short point about what has been said in either the speech or in the debate so far. There are no POIs in reply speeches.

The idea is to test the speaker's ability to deal with unforeseen aspects that hadn't been taken into consideration and to become a bit side-tracked by the opposing team. POIs are expected to be offered from both teams.

The speaker can either accept or decline a POI. It is expected from every debater to **accept at least two POIs** per speech. Accordingly, the opposing team has to offer enough POIs to the speaker (two at least per person). Not doing so will result in lower scores. Every debate member's involvement in the debate should not end with delivering his or her own speech.

More on POIs

<http://www.schoolsdebate.com/docs/notes.asp#POIs>

<http://debateable.org/debate-topics/points-of-information>



Pic. 4: A debater offering a POI to the speaker



Pic. 5: A typical debate layout

## 1.4 The cast involved in debating

Debating is a team sport, and as it is the case in many sports, there are always people involved at both the front-end and back-end.

### 1.4.1 The debaters

At the frontend you have the debaters, also called *speakers* or *players*. It is pretty obvious what their task is. A debater has to prove their worth in the categories of **style, content and strategy**, which are the three components of the decision-making process in the WSDC format. A debater's performance will depend on research, selecting material and data, adding structure to the speech, preparing his or her line of argumentation and generally showing public speaking skills in front of an audience. For more on speaker roles see 1.5.

### 1.4.2 Chairperson and timekeeper

Every debate has a chairperson. He or she takes the role of a moderator, introducing the proceedings of the debate, the names of the teams, speakers, judges and, if present, the timekeeper. The info should be displayed on either a blackboard, flipchart or even laptop/projector, if available. The info provides some assistance to both the audience and the judges about who's currently speaking and where we are in the debate.

If the event lacks personnel, chairpersons can be timekeepers at the same time. At some tournaments, team members not speaking the round can take over these roles as well.

The timekeeper, well, keeps the time, using a timing device (stopwatch, mobile phone...) and either announces the debaters' speaking times orally and/or writes them on the classroom blackboard or any other surface that can be used as a display.

Most importantly, however, the timekeeper gives audio signals to announce certain crucial time limits in a debate. A *substantive speech* lasts eight minutes in the WSDC format. *Reply speeches* are half the time, i.e. four minutes. The timekeeper can either bang, knock or smack on the table surface or use some sort of softer sound-producing device, such as a small bell or bike bell to announce the following times in the following fashion:

Minute	Substantive speeches (PROP/OPP 1-3)	Reply speeches
1'	one ring to announce end of protected time (from POIs)	-
3'	-	one ring to announce last minute
4'	-	two rings to announce end of time
>4'30"	-	continuous ringing until speaker stops speaking
7'	one ring to announce protected time / last minute	-
8'	two rings to announce end of time	-
>8'30"	continuous ringing until speaker stops speaking	-

*Fig. 2: Timekeeper's audio signals*

As such, both chairperson and timekeeper assist the judges in making sure that all the names are taken correctly and that the debaters keep the speaking time limitations. The duration of the speech is also crucial to the marking of the individual debater.

→ Also see Appendix: Chairperson's speech (xiii)

Team PROP <Name>	<Tournament name> <Round No.>	Team OPP <Name>
1st Dennis 6:40 2nd Melanie 7:55 3rd Peter 8:33  reply: Melanie 3:56	Motion: THBT smoking in public places should be banned	1st Hakan 8:02 2nd Claire 7:55 3rd Lena 7:00  reply: Hakan 4:12

*Fig.3: Typical info displayed by chairperson and timekeeper, see also pictures on page 7*

→ Also see Appendix: Time cards (xv-xvi)

### 1.4.3 The judges

There are a minimum of three, and always an uneven number of impartial *judges* or *adjudicators* in the room. They watch the debate and have to assess to what extent the teams have performed their respective roles as either *proposition* (PROP) or *opposition* (OPP) in terms of style, content and strategy, whether the timing was alright and whether enough *Points of Information* (POIs) have been exchanged.

Judges fill in a mark sheet, come to an *individual decision*, leave the mark sheet in the room and meet the other judges outside the debate room. There they exchange and discuss their decisions, based on which observations they have made. The Chief Adjudicator or *chair* announces the result of the debate. It can be either a *unanimous* (3-0) or a *split decision* (2-1). The judge not voting in favor of the winning team is called the *dissenting judge*. If the Chief Adjudicator is the dissenting judge, he can choose to delegate the *adjudication speech* to one of the other two.

In opposition to other styles, like British Parliamentary, the WSDC format doesn't feature a *consensus decision*, in which the judges decide co-operatively on who to give the debate to.

Judges are also strongly encouraged to give feedback to the debaters after the debate and to explain to them why the decision went to either of the two teams from their points of view. Giving judges' feedback is the **core educational element of debating**. If debaters cannot profit from the input on what they can do better in the future, they can't improve and may become wary of debating. This should be avoided at all costs. Feedback should be constructive, objective and not meant to make debaters feel bad about themselves. More on judging later.

### 1.4.4 The coach

The coach assists the speakers in creating their case, arguments, reasoning and finding examples. The coach has a more distant view of the case-making process and, as such, is guiding the debaters towards what could be the best approach on the discussion matter. Coaches are predominantly there to set a schedule for preparation sessions, to motivate the debaters to prepare their speeches and also to witness the debate and tutor them afterwards.

Whereas the debaters also receive feedback from the judges, the coach is a lot closer to the development of the case and in combination with the judges' feedback can explain better why things have either worked out or why they haven't, and which improvements can be made in future debates in consequence.



The coach also has responsibilities as a custodian at tournaments, especially with minors involved. Depending on experience, coaches are mostly asked to judge as well.

### 1.4.5 The audience

It's always nicer for the debaters not only to speak to the judges and team mates, but to an audience as well. If there is debating going on in your school, you might want to advertise it on a wider scale to encourage outside visitors to attend the debates. The audience can be seated in front of the judges (see Fig. 1, p.8).

This is a **great chance to draw the school community together!** Debates can be watched by the debaters' teachers, school and parents' representatives, local politicians, financial sponsors, family and friends. The motions can be publicly announced on posters, the school's webpage and maybe even in the local newspapers in order to draw attention to the event.

Debating events are usually free of charge, but that's at everyone's own discretion.

### 1.4.6 The tabber

Every tournament has a person or small team in charge of entering and adding up the results written on the judges' mark sheets and publishing the *team ranking*, ideally in between each round, as well as the *speaker ranking* to determine the best tournament speaker, a practice known as *tabbing*. The associated *tab room* is off-limits to debaters and coaches.

Pics. 6-8: Impressions from the German Schools Debating Championship (GSDC) in Berlin, May 2012



## 1.5 Speaker roles

### 1.5.1 First PROP

#### 1.5.1.1 Defining the motion

The first speaker of the PROP opens the debate. First of all they will have to define the motion. In the given example "THBT smoking in public places should be banned", there is a great need to define the terms *banned* and *public places*. How would this ban be carried through? Which effect will be achieved? With public places, are we talking about train stations or schools or parks or rock concerts or all of the above? Would the team like to exclude certain areas for any particular reason?

The line of argumentation must be in accordance with what side PROP believes to be the right public places, be important and vital enough for their case to be taken seriously, but not too absolute to be unrealistic in its goals. This is tricky. If you would like to restrict *public places* to kindergartens and schools only, in order to protect the health of the young and defenseless, it may not be broad enough to convince a wide audience of your approach on the matter, particularly because it's mostly not allowed there anyway, and also since this kind of definition may not comply with the general perception of *public places*.

Even though it is not entirely necessary to do so, the speaker could also define *smoking*, giving all kinds of examples that side PROP would like to include, such as cigarettes, cigars, pipes and so on.

Generally, however, it is always presupposed that the audience, as well as the judges, are **averagely educated** and that there is a **common understanding** of what *smoking* is, which would make defining the term somewhat irrelevant, but this would be entirely up to the team. If they want to fight a war on pipes only, it may miss the point of the motion, as, once again, *smoking* is generally perceived as smoking cigarettes in public. However, they can try nonetheless, if they so wish, and give it a shot, and if they have enough arguments and evidence to make such a claim.

The opposing team, however, would have difficulties in adapting to such a case, expecting the ban of cigarette smoking to apply pretty much everywhere but home and maybe in one's car, and the judges could therefore declare the *definition* set by side PROP as *undebatable* and award the debate to side OPP.

The practice of shaping a motion into something that cannot be considered the *obvious understanding* of the motion is called *squirreling* and may result in losing the debate.

More on defining motions:

 <http://www.schoolsdebate.com/docs/definitions.asp>

#### 1.5.1.2 Locating the debate

It will almost always prove helpful to focus on certain areas only, since it will be very difficult to solve one issue on a global level. One can either restrict the motion geographically (unless worded in the motion), socially or in political terms. One could use the EU as a parameter or all liberal democracies, or simply one's own country, as is common practice for younger debaters in years 8 or 9.

One could also restrict the motion to an age group, gender, social class or other parameters, depending on the nature of the motion. When talking about the environment, one could merely focus on developing countries, for instance, where environmental catastrophes are most abhorrent.

Ironically, the possibilities of restrictions are limitless. Above all, the definitions should be in accordance with the common understanding of the averagely-educated audience and judges.

### 1.5.1.3 Presenting the case and team line

Next, the first speaker will set the framework of the PROP's *case*, explaining and justifying what they are standing for, generally because the status quo does more harm than good, but for other motivations as well. Then he or she introduces the arguments they themselves will talk about, for example health and environment, as well as which arguments the second speaker will address (e.g. social implications). This part of the speech is known as the *team line*.

The first speaker will also introduce the third speaker's role of doing the *rebuttal* of the debate. Either speaker 1 or 2 should be introduced as the *reply speaker*.

No new arguments are allowed in the third speech, unless there is a valid reason, which has to be mentioned by the first speaker as part of the *team line*.

### 1.5.1.4 First arguments

Typically, the first speaker presents the case and the first two arguments, beginning with the most important one because it will be debated most. In the given example of smoking in public places, two main arguments could be related to health and, possibly, environment.

On health, one could argue that passive smokers need to be protected. Studies could prove that smoking passively can be just as dangerous as smoking actively. Spreading cigarette fumes in virtually every openly accessible area could affect thousands, if not millions, of people in society X, especially small children. This can result in high death rates, high health costs and, in the age of ageing societies, can be seen as a threat to the social cohesion of a nation, when all the younger people retire or die early.

On top of that, the waste being disposed of can be seen in streets, public transport and parks etc., therefore making it an environmental issue as well.

The Second speaker will elaborate on the social implications a bit more (third argument).

## 1.5.2 First OPP

The first OPP speaker's task is either to agree or disagree with the *definition* of the *wording of the motion*. The framework set by defining the motion is the terms on which the debate will continue. If side OPP does not address the definition of the motion, it will be considered as agreeing with it, although putting agreement into words is always the best way.

However, side OPP may add some element to the definition or may even attack it altogether. In the latter case, side OPP will be in the position of having to explain to the panel of judges why the presented definition, for example of smoking, is not a basis profound enough to debate about.

If side PROP continues to insist on its definition and side OPP insists on not agreeing with it, all the participants, including the judges, find themselves in the messy situation of a *definition debate*. This should be avoided at all costs. The chances are small that there may be a clash of arguments to follow, since all the arguments are based on two entirely different principles. Depending on how the PROP has defined the motion, side OPP may end up losing the debate, if the judges find the PROP definitions acceptable.



The vast majority of debates, however, will see sides PROP and OPP agree on the most reasonable and, for the averagely-educated person, most generally understandable wording of the motion, so here's what the 1st speaker OPP should do in a normal debate:

- deal with definitions
- rebut First PROP's substantive arguments
- outline case division for OPP
- deliver 1 or 2 substantive arguments opposing the motion

The following examples of possible responses are entirely off the top of my head.

There are numerous examples of people who, while having been smokers most of their lives, were still able to reach high age and die natural deaths. So there may be a health hazard, but it's absolutely not going to end this way for everybody. Besides, there are a lot more pollutants in the air, for example from cars, especially in urban areas, especially at eye-level for small kids, which are just as hazardous or even worse. Should we not rather consider a ban on cars from public places then as well? Surely, this can't be the case. (...)

The time used for rebuttal and constructive arguments should ideally be around 35% for rebuttal and 65% for the substantive parts of the speech.

After rebuttal, the First Speaker OPP may now present their *constructive arguments*, which aren't aimed at what has been said by side PROP, but are defending the status quo.

To smoke or not to smoke is a decision that every person should be allowed to make themselves in liberal democracies. Banning smoking in public places could therefore be seen as an infringement of the individual right of choice.

A possible OPP defense could draw the picture that there have been enough anti-smoking campaigns in the recent past and that this could still be increased even more and advertising has already been pretty much banned from all public spaces. In Germany, for instance, it takes ID that proves your legal age to buy cigarettes and that the bar is quite high enough as it is to get your hands on cigarettes, so that passively, non-smokers' protection still increases, which leads to the conclusion that rather than banning smoking entirely, more efforts should be put into anti-smoking awareness, in order to achieve a reduction of exposure to cigarette fumes in the long run.

For economic reasons, smoking can't be banned entirely from the public sphere anyway (a too perfectionist approach), and especially from bars and restaurants that depend heavily on smokers as customers etc. On top of this, the tobacco industry employs thousands of workers. A ban on smoking, even only in public places, will hit the industry heavily and would see people losing their jobs.

So, where did the First OPP make his mistake? Correct, he didn't attack the environmental issue. The speaker therefore concedes that this point can't be rebutted, which is left standing. A good second PROP speaker will not tire at pointing that out.

"Deatabase": prepared pro and con arguments for popular debate topics

 <http://idebate.org/deatabase>

### 1.5.3 Second PROP

Since there is usually just one more argument to deliver, Second PROP is expected to use about half of the speech rebutting what First OPP has said and what he missed saying. There should be at least one more argument. The balance of rebuttal and substantive arguments should be around 50/50.

### 1.5.4 Second OPP

Since there is usually just one more argument to deliver, Second OPP is expected to also use about half of the speech rebutting what First PROP and Second PROP have said. There should be at least one more argument. The balance of rebuttal and substantive arguments should be around 60/40.

### 1.5.5 Third PROP

Third PROP will only do rebuttal on what has been said on side OPP. There are no more arguments in the third speech. One mustn't forget to constantly link the line of arguments to the framework of the case repetitively. About 80% should be devoted to rebuttal and 20% to establish the link to the relevance of the case.

### 1.5.6 Third OPP

The same mentioned in 1.5.5 applies to the third speech of the OPP. Technically, third speakers don't need to do as much research as first and second speakers need to conduct, at least not for the sake of their own speeches. Most coaches, of course, will insist on every member of the team to contribute to preparations. However, a good third speaker will show the ability to analyse new examples (not arguments!), while referring to important issues that came up in the debate.

Third speakers, need to be very observant to what has been exchanged in the course of the debate and mustn't forget any issues raised by the opposing team, be it PROP or OPP. Simply pointing out why your case is better won't be good enough, you will have to point at what is bad about the other side's case as well.

Lecture on note taking in WSDC (for debaters)

 <http://vimeo.com/13410644>

### 1.5.7 OPP and PROP reply speeches

Reply speeches are intended to take a big step back and to look at the debate from a bird's-eye view. Trying not do any rebuttal and simply showing the areas of contention is often a thin red line that in some instances can't be avoided crossing. However, the purpose of the reply speech is to give each team the chance again to take a more philosophical approach to the clashes of the debate.

Some speakers use analogies to compare, for example, the PROP to a lion, whereas side OPP was behaving like a peaceful bird. A very popular analogy is also the house that has been built on a stable foundation, whereas the other house (the opposing team's house) has now collapsed and crumbled under the weight of the own team's argumentation.

→ 2.6 Creating reply speeches

→ Appendix: Useful phrases for debaters (xi)

More on speaker roles

 <http://debateable.org/debate-topics/speaker-roles>

 <http://www.schoolsdebate.com/docs/notes.asp#SpeakerRoles>

<b>1st PROP</b>		<b>1st OPP</b>	
definition, case, team line,	6-7' substantive arguments	2-3' address definition, case, rebuttal	5-6' substantive arguments
<b>2nd PROP</b>		<b>2nd OPP</b>	
4' rebuttal	4' substantive	4-5' rebuttal	3-4' substantive
<b>3rd PROP</b>		<b>3rd OPP</b>	
6-7' rebuttal	link to case	6-7' rebuttal	link to case

Every speech should end with a short summary of what has been said

*Fig.4: Approximate use of speaking time in substantive speeches*

To wrap up what you've been reading so far, it's helpful to follow the link and watch "An introduction to Debating" by QatarDebate.

**Please note** that PROP and OPP are seated on the **wrong sides in this video!** PROP should always be (and always is) seated on the left-hand side of the audience.

 [QatarDebate An introduction to Debating](#) on the DSG server (1:01:29)

A lecture on the WSDC format, also wrapping up pretty much everything you've read so far

 <http://vimeo.com/13273227> (1:01:19)

## 1.6 Viewing a debate online

This debate was staged as a training film for beginning debaters by QatarDebate, featuring world-renowned speakers.

**Please note** that PROP and OPP teams **are sitting on the wrong sides!** PROP should always be (and always is) seated on the left-hand side of the audience.

- For training reasons, speaking time has been reduced to 5 minutes (instead of 8) and 3 minutes for reply speeches (instead of 4).
- The motion is "THW ban smoking."
- Note the use of POIs.
- Note the use of courtesy in response to POIs.
- Note how teams point out the other team's flaws.
- Also note the audio signals given by the timekeeper to announce the end and beginning of *protected time* from POIs, as well as the end of the debater's speaking time (claps).
- The film features model feedback for all the speeches seen here.

 [QatarDebate THW ban smoking](#) on the DSG server (1:02:03)

Find more debates online here:

 /  <http://debateable.org/media-gallery>

## 1.7 Judging

Before talking about the tasks of a judge, or *adjudicator*, one must know that nobody is born a judge, but that virtually anyone with good enough English and the willpower to do so can become one. Very much like debating, judging, unfortunately, can only be learned on a step-by-step basis. Becoming confident in the practice of adjudicating will gradually develop by sitting through tournament *judges' briefings* and gathering experience as a *shadow judge*, who is allowed to participate in the discussion, but whose decision doesn't count.

Inexperienced judges will get their chance possibly two or three rounds into any tournament to judge as a third of three judges. It can't be avoided to be thrown in at the deep end at some point, but once that has happened, people usually catch on quite fast.

Simply put, no two judges observe the exact same things in a debate. Everyone has a different approach, expectation and perspective on it, which is why there are always an odd number of judges in the room (usually three in preliminary rounds and respectively 5, 7, 9, maybe even 11 judges in the knock-out final rounds) to allow a majority decision in any case.

What will be expected from everybody, however, is that the decision you make can be justified reasonably. Why giving it to one team rather than the other may come down to only one aspect of the debate. Why this aspect is crucial enough to give the debate to either of the teams is a question you'll have to answer satisfactorily to a) the debaters and coaches and b) to the tournament *chief judges*.



Pic.9: Five judges in a quarter-final at EurOpen 2011 in the greater Stuttgart area (here: Esslingen)

### 1.7.1 The marking standard

The three categories in which marks are allocated are *style*, *content* and *strategy*. A maximum of 40 points can be allocated to style and content, whereas strategy can only have half of that, or 20 points. This adds up to 100 points max for substantive speeches.

Reply or *summary* speeches can only be awarded half this score, or 50 points in total.

However, the range in which marks are given almost never go below 60 or over 80 in substantive speeches. An average speech that fulfills all the requirements, and receives the quality "good" has 70 points (28/28/14). An overwhelmingly good speech at WSDC final rounds receives about 77 or 78 points.

You can always give half points to every mark (28.5/27.5/7.5).

### 1. Substantive speeches (out of 100)

Standard	Style / 40	Content / 40	Strategy / 20	Overall / 100
Exceptional	32	32	16	80
Excellent	31	31	15-16	76-79
Extremely good	30	30	15	74-75
Very good	29	29	14-15	71-73
<b>Good</b>	<b>28</b>	<b>28</b>	<b>14</b>	<b>70</b>
Satisfactory	27	27	13-14	67-69
Competent	26	26	13	65-66
Pass	25	25	12-13	61-64
Improvement needed	24	24	12	60

half points may be given

### 2. Reply speeches (out of 50)

Standard	Style / 20	Content / 20	Strategy / 10	Overall / 50
Exceptional	16	16	8	40
Very good to excellent	15	15	7.5	36-39
<b>Good</b>	<b>14</b>	<b>14</b>	<b>7</b>	<b>35</b>
Pass to satisfactory	13	13	6.5	31-34
Improvement needed	12	12	6	30

half points may be given

*Fig.5: The marking scale*

The winning team *must* have more points than the defeated team. It is absolutely legal to manipulate points you may have already entered into the mark sheet to set that straight. It is therefore recommended to enter the scores *after* the debate

- because you avoid making too many corrections
- and it therefore looks nicer on the sheet and is easier for the *tabber* to read
- and because it is a matter of respect to listen to the last speech with the same kind of attention with which you have watched the whole debate, even though you may have already determined a winner.

As you take notes during the debate, or *flow* the debate, you might want to write down possible scores in advance and finalise the decision after the debate has ended.

In other formats, like the Karl-Popper Format, there is a feature called *low point win*, which means that in rare occasions, the team that has scored fewer points may still be awarded the debate for various other reasons. This is absolutely not allowed in WSDC.

Every speaker has a "credit" of 60 points, regardless of what will happen in the debate. The most popular example is the debater who gets up, stands in front in the audience, turns green in the face, runs out of the room and doesn't come back. That's 60 points. The reasoning behind this is that by losing 10 points to a good speech (or 70 points), it will be overly difficult, if not impossible for the other two team members to win the debate, even though it potentially could still go on.

You will be asked on the mark sheet to add up all the points, so that the team's total performances can be seen in numbers. As said before, the winning team must always have more points than the other, even if it's only half a point.

### 1.7.2 Judging Style

Style, essentially, is about delivery of content and strategy. Most importantly, the speaker should be audible, clear, keep eye contact with the audience and judges and shouldn't make any hectic, distracting moves. Additionally, the speaker should adhere to courtesy towards the other team.

*Style* is the most subjective of the categories, but also should be assessed free from any prejudice towards character, origin, gender etc. Depending on which cultural backgrounds speakers may have, they may vary in speaking speed, accent and the use of palm cards or large sheets of paper.

What you are generally looking for is a person who can attract the attention of the audience by his or her sheer quality of presenting him- or herself as an orator, doesn't fear speaking in front of an audience, isn't side-tracked by POIs and has complete control over everything that is happening during his speech, which predominantly shows through a tidied-up mixture of rebuttal, substantive matter, POIs and other traits, such as quick-wittedness and humour.

People with low style marks usually show signs of insecurity, constantly stare at, hide behind and/or shuffle through their notes and palm cards, get lost in their own speech, speak very quietly, with little or no gesture and facial expressions.

On the other extreme end, one shouldn't be overly aggressive either, snapping and yelling at the opposing team, sneering insults and show emotional discomfort with what is happening in the debate.

Marks shouldn't go below 26 in style or exceedingly higher than 30 or 31 per substantive speech. In reply speeches, the margin is 12-16.

### 1.7.3 Judging Content

Content primarily assesses the quality of what has been said in the debate. Any motion can have various arguments to speak for or against it, but what matters is whether the arguments chosen are logical, necessary for achieving the team's aims and linked to the overall framework or *case* (or *model*).

In the example of "THBT smoking in public places should be banned" from 1.5.1, the environment issue may have come across as a bit weak, since littering through smoking may not be such a vital contribution to the case as health to society is. Therefore, choosing "health" as a core argument, along with social implications can be considered logical and purposeful.

The most important argument should be mentioned first, as this will be expected to be most debated over from both sides.

Still, if an argument is weak and the opposing team does not clash it, it remains standing. Even a claim such as "*There are 300 human clones walking the planet's surface*" and the OPP team does not address the matter, side PROP should still get away with it. It may wrench any judge's guts, but it is the OPP's task to be aghast, appalled and set the matter straight, not the judge's!

Therefore, the judge ultimately assesses only what is happening inside the debate, not inside the judge's head. One's own specific knowledge, as well as substantive matter that you firmly believe should have been part of the debate, must be ignored. What matters is whether the opposing team has brought that particularity up or not.

Some may be blinded into giving a speaker overwhelmingly good marks for his or her excellent speaking style in content as well, whereas on the content level, selection may have been poor. One can still mark the speaker high in style, but content must be seen entirely disconnected from it. If most of the things talked about miss the core of the matter or are otherwise poorly chosen to reach the team's aims, especially in connection with a case improbable of reaching a broad appreciation, the judge should show this by marking the debater down in content, despite his charming performance.

Content also includes weighing the balance between rebuttal and clash, whereas this is the point where one could make that a *strategy* issue as well. Still, if the second speaker OPP does rebuttal only, without giving his speech any extensive substantive matter, this obviously shows weaknesses in delivering content as well.

Marks shouldn't go below 25/26 in content or exceedingly higher than 30 or 31 per substantive speech. In reply speeches, the margin is 12-16.

#### 1.7.4 Judging Strategy

Strategy in WSDC mostly deals with timing as well as prioritising and linking the issues correctly. An OPP speaker rebutting the most important arguments poorly will be marked down in content, but in terms of *strategy* the debater has depicted the correct areas of contention that needed to be addressed.

All arguments, reasons for these arguments and examples chosen must be coherently linked, should always be in accordance with the case and follow the logical structure of putting the most important arguments first. There is an expected amount of both substantive matter and rebuttal, as well as satisfactory use and response to POIs.

Debaters are marked down in strategy if they go excessively over or stay below allowed speaking time and whether organisation came across as not easily understandable, avoiding using so-called *signposts* about where the speaker is at in the debate ("I will now get to my second point", "...which brings me to the next argument of..." etc.).

A debater should present a concise speech, with an introduction, a main part and a nice wrap-up, mostly done through summarising what has been said. It is weak strategy if the debater keeps going back and forth in between the same points, or uses them repetitively. They should be dealt with one by one in a successive fashion.

The case must come across as conclusive. It is the debater's task to *connect the dots*, or linking content logically. If there are scattered points that have good relevance to the motion, but are otherwise not coherent with each other, or the other team members' speeches, the judge must be careful not to draw the conclusions himself and mark the speech up. This also has to be done by the debater through *signposting* and summary.

It is also imperative that speakers keep in line with the case of their side. If they contradict their own case or arguments brought up by other members of their team, this shows a huge lack of consistency and therefore strategy.

Strategy marks never go below 12 or higher than 16 points per substantive speech. More variety is possible by using 0.5 points as well. In reply speeches the margin is 6-8.



Summing up, a judge should ask himself:

- Did the speaker have a convincing and persuasive appearance?
- Did the debater make appropriate use of the palm cards or sheets (did they present the argument or read out the argument?)
- Did I like to listen to him/her?
- Was I able to follow?
- Did the speaker make it easy to follow (with sign-posting, clear voice, gestures and facial expressions, adequate speed and use of vocabulary)?
- Did the speaker deal with POIs in a polite but persuasive manner?

Content, style and strategy according to the WSDC Notes for Adjudicators

 <http://www.schoolsdebate.com/docs/notes.asp#Content>

Video lectures on WSDC judging

 <http://vimeo.com/13412319> (39:32) <http://www.youtube.com/watch?v=GVx9AaPkm4E> (38:32)

Adjudicator training at WSDC 2014 in Bangkok, Thailand

*Chief Adjudicators* tutor judges who are new to the championship.

 [WSDC 2014 adjudicator presentation](#) on the DSG server (1:12:41)

WSDA 2010 Final (World Schools Debate Academy)

Compared to the other step-by-step introductory films, this recording shows you a full 8-minute speech debate. The result is displayed below the video.

 <http://vimeo.com/13264166> (1:01:15)

### 1.7.5 Filling in the mark sheet

In this particular example (next page), side OPP wins the debate by a margin of 9.5 points, which is relatively high.

The second column on the right is known as the *POI adjustment column*. It is used to either add or take off points if a POI following one's speech has been entirely different in quality than the speech itself.

In this shown case, a relatively strong speaker (Hakan) has unfortunately offered a somewhat weak POI after giving his speech, so 0.5 points have been taken off.

The POI column is only to be used if a particularly weak speaker offered a very good POI instead, or vice versa, but is very rarely used. The rest of the mark sheet should be self-explanatory. The Winner Team should show the side it debated on (OPP) as well as the team's name (Schiller-GYM), just to be sure that the right team has won.

Regardless of what the mark sheets say, the *verbally announced team* has won the debate, even if the judge gets it wrong (yes, that has happened occasionally - we're all human after all).



# Senior League Bawü/Hessen 2011/2012



## MARKSHEET

Proposition Team:	Goethe-Gymnasium, Musterhausen	
Opposition Team:	Schiller-Gymnasium, Musterhausen	
Date:	12 OCT 2011	Round: 1
Motion:	THBT smoking in public places should be banned	
Judge:	Sabine Musterfrau	

### Proposition Team

Name of speaker	Style/40	Content/40	Strategy/20	POI Adj.	TOTAL/100
1. Dennis	28	29	13.5		70.5
2. Melanie	28.5	29	14.5		72
3. Peter	29	28.5	13.5		71
Name of reply speaker	Style/20	Content/20	Strategy/10		TOTAL/50
Melanie	14.5	13.5	6.5		34.5
Proposition team total/350					248

### Opposition Team

Name of speaker	Style/40	Content/40	Strategy/20	POI Adj.	TOTAL/100
1. Hakan	29	29.5	15	-0.5	73.0
2. Claire	29	30	14.5		73.5
3. Lena	30	29.5	13.5		73
Name of reply speaker	Style/20	Content/20	Strategy/10		TOTAL/50
Hakan	14.5	15	7.5		37.5
Opposition team total/350					257.5

Winner team: Opposition (Schiller-Gymnasium)
Judge's signature: 

©2011 Debating Society Germany e.V.

Fig.6 : Mark sheet

## 2 Debate club implementation

Right! Now that your brain has been bullied into processing all the theory, let's look at a few practical exercises that keep your students busy and active. Attending a debate club will imply that this is exactly what they want. They don't just want to sit there doing nothing, but rather start talking about interesting motions. But first, you will need a group of pupils to begin with.

### 2.1 Acquiring debaters for a club

The 1984 science-fiction film *Dune*'s first lines are "A beginning is a very delicate time", and in case of debating I couldn't agree more. Trying to find followers for a project most pupils may have never heard of before, is not the easiest of challenges.

In most schools, pupils already in existing clubs are also the ones who spread the word, in my school even walk to classrooms and get the teacher's approval to say a few lines about their debate club before a lesson starts. In the case where there aren't any club members yet, you are pretty much on your own. Here are a few tips on changing that:

- Tell your own students in class and ask them to spread the word
- Approach students of whom you think would make good debaters individually
- Make posters describing the benefits of debating and announce a meeting point and time
- Make copies of an announcement sheet and put them into class registers for colleagues to read out to classes
- Pick classes that are your target age group: Beginners (mostly year 7), Juniors (8 and 9), Seniors (>10)
- Announce it on the school's webpage
- Approach colleagues to spread the word in other tutor groups and clubs
- If there is a regular newsletter or year book at your school, put an article in there

I'm sure there are many different creative ways at many different schools to draw attention to your club or project, which are too numerous to mention here. If you want to share more of these ideas, please let us know.

#### 2.1.1 Bottom-up or top-down?

It's difficult to recommend a specific age group you want to start with. If you open a club for beginners only, for whom there is no tournament for, you'll be pretty much disconnected from actively participating in debating events, but admittedly get more acquainted with the materials first. Gathering first-hand experience may be more difficult, but you could of course take your students to events for, say, Junior League and have them watch debates and get experience from there. They will witness that even active participants still have their difficulties to challenge. Downside: you lose a year or two.

On the other hand, if you start with a Junior or Senior group, you already may have very proficient speakers of English, making catching up and gathering experience a fast process, which they in return can pass down to younger groups (see 2.1.2).

In either case, you should overcome any fears and start participating in tournaments instantly! Don't think your team isn't good enough, so participation wouldn't do any good but making fools of yourselves. Admittedly, it probably may not be easy for them, but EVERY team started that way: participating, losing, learning, improving steadily.

Experience tells me, that new teams are welcomed with open arms by other debate teams and organisers. Everybody involved has gone through the same difficult stages of becoming acquainted with the practise of debating and will offer all the assistance you need.

In debating, there are only winners and learners. Remember: you only learn debating through debating.

### 2.1.2 School and university student instructors

Some teachers tutor all debating groups (Beginners, Juniors, Seniors) on their own, whereas others have a colleague or two who is helping out. It is a very vital contribution to let school students who have experience in debating do the tutoring for Beginners and Juniors. They are instructing on the same eye-level, at least closer than teachers, and pass on knowledge on a first-hand basis.

If you have a school nearby that already has debating in place, you could ask some of them over to give first ideas on how to approach the issue.

If you have a university nearby, chances are increasing rapidly in Germany, that it features English-speaking debating. It is in their interest as well that school students are introduced to the trade of debating and would most likely gladly help you out.

You can contact university debaters through the *Verband der Debattierclubs an Hochschulen (VDCH)* on their webpage.

VDCH - Verband der Debattierclubs an Hochschulen

 <http://www.vdch.de/>

## 2.2 Debate club curricula

Generally speaking, debate clubs meet for games and practice (see section 2.3) and for practice debates (see section 2.4).

Once you have signed up for a tournament or league, you will be facing a motion. Once that happens, this is typically the work ahead:

- Meet regularly for preparations and practice
- Do research on the topic
- Define the wording of the motion
- Find arguments
- Find reasons for these arguments
- Find examples to support these arguments
- Finalise the case
- Assign debaters to speaker positions
- Have debaters structure their speech
- Have debaters write palm cards

At all tournaments in Germany, as well as at WSDC, the side your team will be debating on will be given to you a few weeks before the respective round starts. They will be published in the *draw*.

### 2.2.1 Beginners (year 7)

Beginners first need to be familiarised with the technicalities of debating in general. Why should one do debating in the first place? Where is the benefit? How does one not get frustrated by it?

Teachers should always convince beginners of overcoming the fears of speaking in front of others and that nobody, even talented kids, are born orators. This is something that comes through practice only, and just like learning a musical instrument, repeated practice, drills and games will eventually make pupils feel better about addressing an audience.

Please remember to be constructive and positive in your feedback, especially when kids feel most frustrated. No matter how high frustration is, every debater had to overcome it at some point as it is a totally natural process. It is not quitting, but doing something about it that keeps debaters going.

Principally, one needs to present beginner debaters with the procedures and roles mostly covered in chapters 1.1 through 1.6.

Depending on how many times you meet and how fast your students are picking up, you can use any of the materials from this book or other means you are best acquainted with from your own teaching experience. The following are simply suggested sheets you can also use as transparencies.

→Use Teaching Sheet 1: "What is debating?"

First steps towards public speaking and debating can develop in this order:

- Preparation of content
- Filtering out key elements
- Preparing notes
- Speak freely with good delivery

→Use Teaching Sheet 2: "How to speak in front of an audience"

You will find more useful documents in the Appendix, such as "*Useful vocabulary for debaters*" that can be used at any level. Take some time to go through it bit by bit and practice pronunciation until the kids get acquainted with linking words etc.

→Use Teaching Sheet 3: "First speeches"

→Use Teaching Sheet 4: "Public speaking feedback form" for coaches and co-debaters

- Listen to the other side and respond

→Use Teaching Sheet 5: "Practice debate"

Try and have as many debates as possible with 3 to 6 minutes of speaking time. If you have enough debaters for two groups try and have them debate each other.

## 2.2.2 Juniors (years 8 and 9)

Juniors, depending on skill level, may already be able to do the debating games as described in 2.3.1 to 2.3.3. Some may have been through learning the technical concepts of debating as participants of the beginner group. However, if they join during Junior level, their English should be developed enough to speak freely about a specific topic.

Most elements used in the beginner groups (2.2.1) can be repeated here and also used as practice, with the addition of *Icebreakers*.

Except for practice debates, Juniors are now officially allowed to participate in DSG Junior League (JL), wherever possible (currently Baden-Württemberg and Saxony).

If you are at an isolated school with few or no schools in the vicinity with whom you can have debates with, you may want to just practice debates as much as you can in your own group and still try to attend the national finals, which, admittedly, might be quite a big step and needs to be coordinated with DSG Junior League National.

✉ Send an e-mail to [jlnational@schoolsdebate.de](mailto:jlnational@schoolsdebate.de) for further info on participation.

✉ If you are either in Baden-Württemberg or Bavaria you can contact DSG Junior League South or DSG Junior League Saxony: [jlsouth@schoolsdebate.de](mailto:jlsouth@schoolsdebate.de), [saxony@schoolsdebate.de](mailto:saxony@schoolsdebate.de)

Juniors should start practicing WSDC formats as soon as they can, but can also do warm-up exercises until they receive the first motions.

Typically, DSG Junior League doesn't start until January into the school year because most schools may just have acquired junior debaters and still need some time for team building and orientation.

Some practices preceding participation could consist of:

- Argument development using
  - SPERM model (2.4.1)
  - ARE / SEE model (2.4.2)
  - Multi-argument development drill (2.3.5)
  - Four-step refutation (2.3.6)
- Speaking qualities
  - Games (2.3.1 - 2.3.3)
  - Public speaking exercises (2.3.7)
- Model debates (2.5)

In Junior League, speakers should also be made aware that reading newspapers or online news can prove helpful or even be made mandatory for participation. At the beginning of the club sessions, and for the sake of warming up to speak English, you could talk about current events first.

To make it less time-consuming, the coach can simply bring up the topic he wants to talk about, rather than ask "What's happened recently?". One may only receive little response to this. Rather try something like "What do you know about what's happening in Greece?" or "Do you like Stuttgart 21?" or "Do you know any German politicians? How can their actions affect you?".

Speaking generally, Junior League is also there to acquaint kids with current events in the areas of politics, economy and global issues. It can prove helpful to implement instructions on the following topics:

- Democratic Systems (*Bundes- / Landeszentrale für politische Bildung* publications may be helpful)
- Political institutions
- Legal issues (immigration, equity rights, health systems...)
- Voting systems
- Political participation
- UN, EU, NATO etc.
- Human Rights (Freedoms of choice, movement, development, the press etc...)
- Federalism
- Demographic changes (First World / Third World)
- Economic shifts and trends
- The globalised world

One can now also increase the level of motions. Here are a few examples:

- THBT advertising shouldn't aim at kids
- THW make teacher evaluation mandatory
- THB in patchwork families
- THW ban same-sex marriages
- THBT comprehensive schools are the solution
- THW ban private health insurance
- THBT American democracy s a model for the world
- THW ban Carnival
- THB in patriotism
- THW limit immigration

Junior League groups should aim at having debated three mock debates before entering JL. This is just a suggestion.

On this webpage <http://debateable.org/media-gallery> you can find numerous recorded debates you can watch and get some experience from them, despite, or maybe due to the high level of debating. Even though junior debaters may not always understand everything, they can still gain some familiarisation with the proceedings in a WSDC debate.

You can also implement a system of three debaters per class in every year, who will be debating on a continuous basis throughout a year and then determine a winner per year. This, of course, would require significant coordinating with your colleagues, but would help implement debating in your school as a small year-round tournament. You could use your club meeting times to gather two different groups for a debate.

### 2.2.3 Seniors (> year 10)

DSG Senior League (SL) is currently the highest-leveled debating tournament in a league system in Germany, so groups should be comprised of rather experienced speakers, even though that is not a restriction in any way. You may only have beginner debaters who happen to be in years 10 or over.

In this case, the group would need to get accustomed with the whole discipline of debating on the one hand, but should also sign up for DSG Senior League (SL) to get practice in debating faster on the other. We assume the language barrier is not as high as in beginning or JL groups, so it should be no problem to enter SL.



As there are more experienced speakers of English in the club, you may already want to start dealing with more advanced approaches on the matter starting from point 2.3.

However, any of the games and exercises (2.2) are also helpful for novice, intermediate and advanced groups.

Depending on which state your school is in, SL may begin three or four weeks into the new school year, so preparations must be quite fast.

Suggested materials for Senior teams:

- 2.4 Preparing a debate
- 2.5 Model debates
- Appendix: Useful phrases for debaters (xi)
- Appendix: Chairperson's speech (xiii)
- Appendix: Time cards (xv-xvi)

Here are some model SL motions:

- THBT free trade is good for the developing world
- THW lower the age of criminal responsibility
- TH welcomes the Green upswing
- THBT all European countries should accept refugees from Africa
- THW stop sending humans into space
- THBT the government should be allowed to disable social networks during civil disorders
- THBT capitalism is an enemy of ecology
- THBT there can be no peace in the Middle East without an independent Palestinian state
- THW make voting in political elections compulsory
- TH would ban all speculation on food
- TH fears the rise of right-wing nationalism in Europe

## 2.3 Debating games and exercises

In this chapter, practical implementation in either clubs or classrooms will be presented. Points 2.3.1 until 2.3.3 cover *Icebreakers* to get your debaters started.

*Icebreakers* is a series of recordings made by *QatarDebate* that present warm-up activities that are fun and introduce debaters to using their language skills under debating conditions. The games cater to all three disciplines in debating: Style, Content and Strategy.

The link at the end of this chapter takes you directly to the video.

### 2.3.1 Games for Content

#### 2.3.1.1 *If I ruled the World*

This game is primarily aimed at groups in which all the students may not know each other. This may occur in clubs at your school, where, in Junior League level, for instance, people are drawn together from years 8 and 9.

You can also use this activity as a warm-up for any other group, just to get them used to the condition of having to speak only English for a while.

Students are asked to introduce themselves by names and say one or two sentences about what they would change first if they ruled the world.

- Example: "My name is <XYZ> and if I ruled the world, I would make debating in schools mandatory." Next person: "If I ruled the world I would end starvation." (...)

### 2.3.1.2 Alley Debate

Students stand in two lines, each facing a partner. They are confronted with a dilemma or motion. In the given example, you have found a purse with € 1,000 in it. Will the person keep the money or take it to the police?

One side of the alley speaks in favor of keeping it, whereas the other side comes up with arguments why the purse should be taken to the police.

The first person starts by giving reasons why the money should be kept. Then, the partner opposes him with a counter-argument. Speakers take turns and switch sides in between.

No argument must be mentioned twice, which is why difficulty increases with group size.

If you have too many debaters in your club or classroom, you may want to split them into two or three groups which then can be split into two or three groups facing each other. You should then confront them with a second or third dilemma.

Example alley debate topics:

- Increasing social welfare
- Increasing allowance
- Closing zoos
- Moral courage
- Internet censorship



Pic.10: Alley Debate

### 2.3.1.3 The Why Game

One person stands in front of the group and gives a statement like "I believe we should ban zoos". The audience yells "Why?". To every answer the debater is giving from now on, he will be asked "Why?" until, finally, he runs out of answers.

To add some pressure, you could count per debater how many answers were given that can be considered reasonable and declare the person who could provide most answers winner.

### 2.3.1.4 Condenser Expander

This practice will help students developing an argument, and consists of a team of three players at first, which will then be expanded to four. In Round 1 the three debaters will each give a statement, an explanation to that statement and an example for ten seconds each (similar to the ARE model in 2.4.2).

Any motion can be used as a proposition or *argument* or *statement*.

## Round 1

- Speaker 1: Statement (10 sec): "This house would not award the 2016 Olympics to Qatar."
- Speaker 2: Explanation (10 sec): "There isn't enough infrastructure and resources in this state."
- Speaker 3: Example (10 sec): "Bad experience made when 15 days prior to the championship, it turned out that the Asian Games 2007 could not be hosted."

In the second round, the order will be reversed and speaking time for each player is 10/30/30 seconds, which consequently *expands* the argument.

Speaking time for each person performing these three tasks is 10 seconds.

## Round 2

In reverse order of speakers:

- Statement (10 sec)
- Explanation (30 sec)
- Example (30 sec)

After this, a fourth speaker will be added, the procedure will be just as in Round 2 with the addition of the fourth speaker putting everything into one argument, *condensing* the speeches given in Round 2 into one argument of about one minute.

## Round 3

- Statement (10 sec)
- Explanation (30 sec)
- Example (30 sec)
- Argument (1 minute)



Pic. 11: Condenser Expander

## Round 4

Round four will be conducted just like in Round 3 but in reverse order of speakers.

## Round 5

Rounds 1-4 will be repeated but with three, then four different debaters representing the OPP side of the debate, clashing everything side PROP has said on the content level, but going through the same procedures.

## Round 6

All eight debaters stand facing each other and present their lines of expanding and condensing their arguments. PROP begins, goes through all four speakers, then OPP goes from speakers 1 through 4 as well. It is similar to an Alley Debate (2.4.1.2), with the exception of listening to the full one side first, then the other and are much further developed.

It may become tiring and a bit stressful for the audience to hear the same points made over and over repetitively. Debaters will realise, however, that by repeating everything they say a couple of times

over, they continuously gain confidence and points come across with more security and further developed by every round.

Skill always grows through repetition.

### ***2.3.1.5 Rapid Fire Definitions***

To any given motion, a debater has 30 seconds speaking time to come up with a motion definition (Appendix: Motions (xii)). An opponent from the group will clash the definition after the speech.

After as many rounds of criticism as needed, the debater will have a chance to every time rephrase the definition until everybody can agree with a final version.

### ***2.3.2 Games for Style***

#### ***2.3.2.1 Count me a Story or Joke***

In order to separate style from content, in this exercise content doesn't matter at all, so it doesn't even matter what is being said. Therefore, debaters count from 1 to 10, but must do this in different fashions. You don't have to count to ten only, but to as any high a number you like for your "speech".

In order to create the impression of how things are said one must constantly change voice modulation, pace, volume, gestures and facial expressions. If you want to count to ten in the manner of telling the story, speakers might sound flat, plain and not very loud. If you are telling it in a manner of telling a joke, more excitement is added, breaks to build up tension are added and laughter may also join in.

Many roles and emotions can be used as you count to any number:

- Excitement growing or diminishing
- A joke
- A narration
- Boredom
- A sports commentator or spectator
- A church sermon
- An advertisement
- A teacher giving a lecture
- A general giving a pre-battle speech
- A kid wanting ice cream
- A boss shouting at his employee
- ... any other role or emotion you can think of...

#### ***2.3.2.2 Over the Top***

*Over the Top* follows similar principles as in 2.3.2.1. in this exercise, students sit in a row of 5-8 people and raise the quality of the same phrase, such as "Yesterday, Dennis played chess with a camel", from calm to, for example, very angry, as well as in reverse order. Once again, content does not matter, so any statement will do.

The principle is to lose one's scruples of expressing emotions during a speech. The more you go *over the top*, the less you feel intimidated by your audience.

### 2.3.3 Games for Strategy

#### 2.3.3.1 Rebuttal Practice

Short one- or two-minute speeches are given, for example in favor of re-introducing the death penalty as a deterrent.

Then, 5-6 students are asked to give one line of attack per person. The last speaker sums up all the previous points of rebuttal as part of a rebuttal speech.

#### 2.3.3.2 Lord of the Points

A speaker gives a speech on any topic or motion (Appendix: Motions (ii)) during which the other students who are sitting in a semi-circle are asked to intervene as often as possible and offer POIs. The speaker should try and become more and more extreme in his content. He is asked to accept one or two points and respond accordingly, but should wave down all the other POIs saying "No, thank you". This game is intended to simulate the stress levels debaters are exposed to while being offered POIs. No POI offered should exceed 15 seconds, just like in a real debate.

Debating games and exercises, compiled by QatarDebate

Watch all activities from 2.3.1 to 2.3.3 with real candidates

 [QatarDebate Debating games and exercises](#) on the DSG server (50:21)

### 2.3.4 Other activities to shape the debater's mind

The following activities are intended to train spontaneity, deal with entirely new topics and situations, fast reactions, creativity, speaking freely and link arguments logically for short speeches.

#### 2.3.4.1 Criminal past

This creative game is intended to practise cohesion. Debaters will be asked to think of a crime and the history of how they were motivated to commit it and how they got incarcerated. In groups of four, one speaks to the others, who are simulating a prison parole board, about why he or she should be allowed to get out of prison early.

In order to succeed, the candidate must answer the following questions:

- Name?
- Crime?
- How long in prison?
- Why did you commit this crime?
- How have you planned it?
- Did anyone help you?
- What went wrong?
- How did you get caught?
- How do you feel about it today?
- What will you do first if granted parole?

*Remember: You want to get OUT of prison!*

Every "prisoner" can draw up as crazy a story as he or she can think of. It is important, however, that the story is cohesive and conclusive in the course of events.

The parole board members are then left to decide whether the prisoner shall be released or not.

Before you begin, it's helpful to brainstorm and research a list of crimes in order to have the correct vocabulary at hand. Sadly enough, debaters may be talking about a lot of crimes in their debating biographies.

© (modified) Heathfield, David (2007): Spontaneous Speaking

### 2.3.4.2 Phone terror

This practice simulates multi-tasking which can occur particularly when dealing with POIs.

Groups of three get together and simulate a three-way phone conversation. We assume one person nowadays owns a landline phone and a mobile phone.

The game begins as an ordinary phone conversation, say, between mother and son, when 30 seconds to 1 minute into the conversation the son is called by a friend. In every scenario, the person picking up the phones will be confronted with problems he or she needs to solve during the conversations.

Example: Mother calls to let the son know that he must come home instantly at this late hour. 30 seconds later, a friend calls to convince him to go to a party.

Other examples:

- Mother is called by her little daughter, who wants ice cream. Her boss calls and lets her know that she got fired.
- Husband calls his wife and tells her about a mistress she's been seeing. He wants a divorce. Her mother calls to let her know she's in town for a surprise visit and wants to meet her.
- A man is called by his boss to let him know he's fired. His wife calls to tell him their teenage daughter is pregnant.
- A teenage girl is called by her mother to listen to her complain to her about the boyfriend she is seeing. Her school's headmaster calls her as well about problems that have piled up in school and how she thinks she's going to solve them.
- A neighbour calls about you stealing his newspaper every morning, which of course you haven't. The police calls at the same time to tell you your son's wrecked the family car.

You may come up with all sorts of crazy situations yourself. The more over the top they are, the less they are boring. The person being called should always come to a solution or compromise with the callers.

Please note that not only the victim of *phone terror* needs to be creative in thinking of dealing with the problems. It will also be quite difficult for the callers to repeatedly annoy the victim.

© (modified) Heathfield, David (2007): Spontaneous Speaking

### 2.3.4.3 Impromptu speaking

To debate on your feet means to be creative. Students receive one word or phrase ("The Olympics" or "One man's loss is one man's gain" or simply "Red") and must talk about this for 3 minutes. The debater has two minutes preparation time but is not allowed to use any notes.

Other words could be:

love	The internet	traditions	black
fears	school excursions	having children	getting married
going camping	work life	historic figures	why school is good
why school is bad	food	pocket money	smoking
alcohol	travelling	the future	sports

Surely you can think of many words and phrases as well. Debating coaches should get the chance of being creative as well.

#### 2.3.4.4 Mad discussion

Pairs of speakers receive a random word each. To determine a winner of the following debate between the two, one must be more convincing than the other on why his or her word has had a more important impact on the world. What makes the debate a mad discussion is the arbitrary selection of words, for example: Why are detective novels more important than pizzas? Enjoy!

ships	the wheel	the internet	pizzas
bras	plastic spoons	lampshades	airplanes
coffee	detective novels	stairs	modern art
architects	newspapers	necklaces	white-out
socks	mini skirts	flags	tables
typewriters	dentists	electricity	cars
politicians	ice cream	calendars	TV
windows	money	xerox machines	actors

© (modified) Heathfield, David (2007): Spontaneous Speaking

#### 2.3.4.5 Five words

A pupil leaves the room while the others stay inside and think of five random words. After being allowed back inside, the student has 20 seconds to tell a random story which features all five words.

#### 2.3.4.6 Taboo

Most of you may be familiar with the board game *Taboo* that makes you describe words but doesn't allow you to use key terms that would get the job done fast. It is a very useful tool to learn, broaden or activate synonymous vocabulary.

Apart from buying the English version of it, you can also come up with your own terms that a) need to be described and b) that mustn't be used in the process of describing it.

The speakers are split into two groups, whereas one group leaves the room. Both teams come up with a set of words, places or people that need to be described and create a list of 5-6 words that mustn't be used.

After returning from outside, the team picks a person from the other team to describe a word in 30 seconds which his or her own team has to guess correctly, without using the words written down for him. The teams swap players until they run out of words. The team that guesses most words right wins.



### 2.3.5 Multi-Argument development exercise

According to the ARE model, your debaters are now asked to develop more than just one argument and to back them with reasons as well as examples.

1. Pick any motion (Appendix: Motions (xii))
2. Give debaters five minutes to develop ONE argument for that motion
3. Have them speak for 2 minutes developing just that argument using the technique as described in 2.4.2 (Argument Structure)
4. Give them feedback
5. Tell them to develop a second argument for that motion and do steps 1-4 over again

© Dr. Alfred Snider, University of Vermont

→ Appendix: Useful phrases for debaters (xi)

### 2.3.6 Four-step refutation exercise

Debaters need to be very observant about what the other side is presenting in the debate, regardless of which side they're on. In order to refute an argument, one achieves better scores if dealing with them comes across in an organised and easy-to-follow manner. They should name the argument, disagree with it, give reasons why they disagree with it and conclude why their point of view is to be preferred.

Use the following phrases:

1. They say...
2. We disagree...
3. because... (insert refutation)
4. therefore...

Example: THBT smoking should be banned from public places (OPP refuting)

1. They say that passive smoking is a hazard to society and that some groups of people are affected by it.
2. We disagree with this needlessly negative perception of the matter
3. because first of all, only 20% of the German population, for instance, are actually smokers. That's 80% not smoking. It is impossible to create a fearful picture of a society dying like rats just because one fifth of them are smoking. Besides, the bans and limitations already in place make it virtually impossible to be exposed to cigarette fumes on a regular basis. The numbers of which are so miniscule that one can hardly speak of a negative effect on a societal scale.
4. Therefore, we believe that, whereas there is a risk to some, we see no need to come to such a harsh measure that would create the sheer impossible task of enforcing a ban on smoking at EVERY public place.

A drill could be conducted in the following fashion:

1. Give every team member a motion to create one argument for, as described in 2.4.2 (Argument structure)
2. Split them into two groups, A and B and match pairs of speakers
3. Group A presents its 2-minute speeches on one argument
4. Group B refutes the arguments instantly as described above
5. Now Group B gives their 2- minute speeches
6. Group A refutes the argument instantly as described above

© Dr. Alfred Snider, University of Vermont

- Teaching Sheet 6: 'Fast four-step refutation practice'
- Appendix: Useful phrases for debaters (xi)
- Appendix: Motions (xii)

### 2.3.7 Public speaking exercise

Students give a one-minute speech trying to use their best public speaking techniques. Observers take notes about what could be done better (voice, volume, gestures, facial expressions, position etc.). The debater should give the same speech again, now trying to implement the suggested improvements.

In a second one-minute speech observers take notes on delivery again. This time, the speech is given and only one of the suggestions made is implemented in the speech. Repeat the speech again for all other areas of improvement.

Wait one hour or until the next debating meeting and have them give the same speech again, making sure they haven't forgotten what they've learned.

While you speak, make eye contact with every person and ask them to raise their hands once you did. It simply adds to your style if you keep facing the audience like that.

© Dr. Alfred Snider, University of Vermont

- See Teaching Sheet 4: 'Public Speaking Feedback Form'

### 2.3.8 Definition attack exercise

Take a look at the definition used for these motions, indict it, and propose a more reasonable one.

1. The United States should withdraw from NATO. Define withdraw as reduce 100 troops from Macedonia.
2. USA-EU cooperation on terrorism should be substantially reformed. Define substantially reformed as "discontinue" because the entire "War on Terrorism" is counterproductive.
3. EU citizens receive a superior education to USA citizens. Define superior as costing less money.
4. The EU will be the melting pot of the future as the USA was the melting pot of the recent past. Define melting pot as a diet consisting of many different foods.
5. The civilization that came from Europe is the rightfully dominating force in human culture. Define "rightfully" as "currently."
6. The USA and all EU member states should renounce and disarm all nuclear weapons. Define "disarm" as remove the firing mechanisms so that it would take 30 minutes to reactivate them. They claim to avoid nuclear accidents.
7. Long live free speech on the Internet! Define "free speech" as something you volunteer, something that is not compelled. Do not allow government to force people to say certain things on the Internet.
8. The EU should adopt a Patriot Act of its own. Define "Patriot Act" as a law forcing all school children to recite a pledge of allegiance to the flag of the EU at the beginning of each school day.
9. The EU expansion should be never-ending. Define "expansion" as economic prosperity.

© Dr. Alfred Snider, University of Vermont

## 2.4 Preparing a debate

### 2.4.1 Areas of argumentation (SPERM model)

SPERM is an abbreviation representing the most common areas from which arguments can be drawn from.

- S: Social / Societal issues
- P: Politics
- E: Economy
- E: Environment
- E: Ethics
- R: Religion
- M: Moral issues

Yes, technically it should be SSPEEERM, but that doesn't sound catchy.

Skim over this list of content areas to see from which you can draw arguments from that would best suit your motion and side of the debate.

Example: THW ban beauty contests - PROP

Possible arguments:

- Society:
  - People spend too much time watching *Germany's Next Top Model* and appear at work tired - **Weak argument**
  - Health-threatening to teenagers (bulimia, anorexia, bad role models) - **Strong argument**
  - Society of envy and following wrong goals - **Potentially ok 3rd argument**
- Politics: hardly a political issue - **Weak argument**
- Economy:
  - Does beauty make one rich? Do beauty contests make others rich? If so, it may not be important enough to question the whole principle of beauty contests - **Weak argument**
  - How many jobs are involved? Media? TV? Maybe not that many... **Potentially ok 3rd argument**
- Environment: no - **Weak argument**
- Ethics: not likely - **Weak argument**
- Religion: depending on cultural background - **Arguments can be shaped in some cultures**
- Moral issues: Is it morally right or wrong to use young girls (or boys) in front of audiences and become famous for what they look like? Isn't this discriminating a) for the models and b) for the ones who are left out? **Strong argument**

Admittedly, there are various ways of looking at the issue of beauty contests. You may weigh arguments entirely differently than I do, which is entirely acceptable. You will witness sitting in a group with your debaters and going through this very same process. You will need to prioritise which argument(s) will be strongest and serve your purpose best.

If you have to prepare the OPP side of the debate, you still might want to go through this list from the PROP side's point of view, so that you can get a general idea of what to expect from the other side.

This strategic process will be time-consuming to beginners, but is extremely vital to your preparations and actually part of the whole fun!

### 2.4.2 Argument structure (ARE/SEE models)

According to the ARE procedure students will learn to understand the significance of backing up an argument. ARE stands for **A**rgument, **R**eason for that argument and **E**xample. SEE stands for **S**tatement, **E**xplanation, **E**xample and essentially means the same thing, but is just called differently (see also 2.3.1.4 *Condenser Expander*).

Examples are also known as *evidence*.

Take the motion "THBT smoking should be banned from public places".

One argument could be:

"Passive smoking is a threat to public health"

One reason why you choose this argument could be:

"Because smoking is allowed in public places, virtually everybody could be a victim of passive smoking. Studies show that one's health is at risk if exposed to cigarette fumes on a repeated basis. This harm could weigh heavily on a society if there is no stopping this condition. Health risks such as circulatory problems and lung diseases could be avoided as well as people becoming ill early and drop out of the workforce or even die younger than the average citizen."

Examples to prove this are:

- "Young school kids going to school through train stations, every person commuting to work for that matter could be affected."
- "Waitresses working in restaurants and bars aren't protected from exposure."
- "The city/country of X has seen an increase of lung-related diseases in the period from Y to Z that can be related to second-hand smoking"
- "Component X in cigarettes causes reaction Y in the body, which could ultimately lead to condition Z and possibly death."

How good your examples are and which arguments can be developed from them depends entirely on the amount of research that is done. Most active debate teams would agree that having lost debates did not happen due to the fact that they were weak debaters, but because they have lacked the time or the scope of conducted research.

→See 2.3.5 and 2.3.6 for exercises

### 2.4.3 The case

The *case* or *model* is the general concept on which your team bases its arguments as well as the successive course of the debate. This chapter will follow a model procedure of a case construction on the motion "THW promote the use of biofuels". It is by all means not binding and you may use any procedure that you feel most comfortable with, for example by choosing a different order of steps.

In a debate, the most important argument should come first for the reason that it will be debated over mostly because it needs to be supported most by

- Reasons for each argument
- Examples to support the argument  
→ ARE/SEE rule (see 2.3.2)

#### 1. What to define?

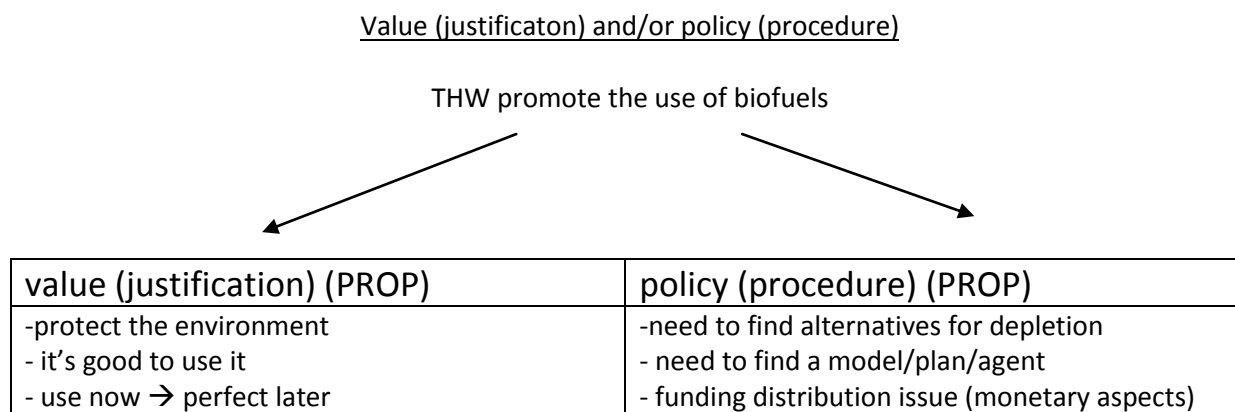

#### 2. Defining the motion

“promote”	“use”	“biofuels”
create a positive conscience of the people	transportation sector only, use as fuel, not as an energy source	everything that is not a fossil fuel -renewable -reusable

#### 3. Which questions to ask?

- Which biofuels exist?
- How advanced has it been researched?
- How much would we need to replace fossil fuels?
- Do we have the capacity?
- How long would it take to develop?
- Are there pioneers / How much is it in use at the moment? (Status quo)

#### 4. Gather knowledge of the status quo (answer questions from 3.)

- from the Internet
- from magazines
- from books
- from TV/online documentaries
- other sources of your choosing

## 5. Find common ground based on research

- 1<sup>st</sup> generation biofuels: made from food crops
- 2<sup>nd</sup> generation biofuels: made from non-food crops (Jatropha, algae, sweet sorghum...)
  - examples: Biodiesel, ethanol, biomass
- Problems:
  - environmental problems
  - cost efficiency
  - energy independence
  - depletion of oil
  - creates markets in dev. worlds → stronger economies (competition w/ Western world)
- Competition w/ other energy types
  - nuclear
  - wind
  - solar
  - “brown gas”
  - geothermal
  - hydro

## 6. Pros and Cons (check opponents' arguments)

PROS	CONS
- renewable (2nd generation) - no pollution (CO <sub>2</sub> – less than fossil fuels) - creates jobs - practiced: can use current technologies (engines) - accessibility → lower prices (economies of scale) - break oil monopoly - constant energy supply → no depletion - energy independence	- deforestation - not totally renewable - biodiversity distraction - inefficiency - lower yields (long-term) - limited space for crops - <i>stagflation</i> ( 1st generation) - food crisis → famines - pesticide use → environmental harm - aggressive farming - impractical for industrialized states - needs for new infrastructure - can't use it in winter - not suitable crops for all climates

## 7. Making a case (here: PROP)

- Final definition of biofuels: 2nd generation ONLY, non-food-based, e.g.
  - algae, Halophytes, small musk grass, Switchgrass, salt marsh grass, Jatropha, sugar cane, sweet sorghum
- based on these criteria:
  - environmentally friendly
  - oil prices go up, supply goes down
  - accessible
  - decentralization of markets
  - independency of fuel supply
  - improved energy security

- define short/long term goals:
  - short term: invest into research, reduce subsidies in Western countries
  - long term: modify, adjust and refine products of research from i., reforestation
- Suitable taglines to present case
  - “Only viable solution based on current infrastructure”
  - “Potential for the future”
  - “With the use of biofuels, we can buy more time until science has found a TRUE alternative”
  - "Rate of change of technology is based on the amount of funding”

#### 2.4.4 Avoiding fallacies

This is a topic that can't be easily practised since this is something the debaters should avoid: logical errors or *fallacies*. The following list gives you a short idea of where typical mistakes can be made.

- Hasty generalisation
- Irrelevant arguments
- Circular reasoning: conclusion is restatement of claim
- Avoiding the issue through
  - evasion
  - attack the person, not issue
  - shifting in principles
  - seizing a trivial point or *red herring* (distract from main issues)
- Appeal to ignorance: failure to disprove is not proof (UFOs)
- Appeal to crowd: majority is not automatically right, may still lack reasoning (Arab Spring)
- Appeal to emotions: no substitute for reasoning (death penalty)
- Appeal to authority: no substitute for reasoning (government decisions)
- Appeal to tradition: no substitute for reasoning (same-sex marriages)
- Appeal to humour: no substitute for reasoning
- Ambiguity and equivocation: different use of words that change meaning (puns)
- Technical terms
- *Post hoc* fallacy: mistaken notion that simply because one thing happens after another, the first event was a cause of the second event
- Damning the origin (for example the Bible)
- Wishful thinking
- Cultural bias
- Pointing to another wrong
- Nothing but objections
- Demand for perfection

Not all mistakes must necessarily lead to penalisation. As said in 1.7.4 (Judging Strategy), it is the opposing team's task to find, mention and attack these fallacies, not the judge's.



### 2.4.5 Preparing impromptu debates

Before an impromptu debate, every team has one hour to prepare its case. More experienced teams know that this one hour passes very quickly and that time needs to be organised effectively.

Inexperienced teams, however, will learn fast about what it takes to structure a debate, assign speaker positions, assign arguments to speakers and provide evidence the more impromptu debates the participate in.

It is useful to split up the hour in different parts:

1. Brainstorming (5-10 minutes) where every team member individually collects ideas, arguments, examples etc.
2. Collecting ideas, building a case (definition etc.) (10 minutes)
3. Outline of the different arguments, order of the arguments, allocation of speaker roles (20 minutes)
4. Speakers write their speeches, others assist (15-20 minutes)
5. Short presentation of the written arguments in order to avoid contradictions or repetitions, team line (5-10 minutes)

This is just a suggestion. Depending on the different dynamics in different teams, other approaches may also work just as well. It is part of the learning process and expedites team building to figure some aspects of impromptu debates out as you go.

For a more detailed approach on the matter, I recommend the following video which shows a workshop discussion for beginner debaters.

More on preparation of impromptu debates

 <http://vimeo.com/13326054> (1:08:28)

## 2.5 Model debates

### 2.5.1 Balloon debate

Imagine your debating club sitting in a balloon, but they are not your debating club but many famous people. Everybody can choose his or her own identity (Mickey Mouse, Michael Jackson, The Queen, Barack Obama, any historical figure...).

The balloon has a hole and is slowly crashing. In order to stay airborne, three or four people must jump out of the balloon to save the others.

In the ensuing debate, you need to convince the others why you deserve to stay alive more than the others. The goal of this macabre role play is to find the certain amount of people (depending on the size of your group) who will be voted out of the balloon. The voted at the end seals your fate. Good luck!

### 2.5.2 Fun Debate

You may have gotten the impression by now that debating is also quite popular because it can also be quite funny, despite the seriousness of some issues that are debated over. just out of plain fun, why don't you use crackpot motions, then?

- THBT Santa Claus is a woman
- THBT boys should wear skirts
- THW be more like Homer Simpson
- THBT anyone can be a teacher
- THBT you shouldn't trust anyone over 30
- THBT sheep would make good pets
- THBT Luke should convert to the Dark Side

→ Appendix: Useful phrases for debaters (xi)

### 2.5.3 WSDC Mini-debates

At this point, even beginners should be able to conduct first model WSDC debates without having to fill eight minutes of speaking time. But who knows? With enough material at hand, some beginners may find themselves even lacking the speaking time they have to fit everything into it.

In some cases you may find yourselves having too much evidence to put into your debates and having to scratch material, therefore having to make the sadistic choice of giving up parts of your case that originally took quite much work but now appears redundant or not catching up with the dynamics of your changing strategy anymore.

However, using any given topic (see Appendix: Motions (xii)), one should just give it a shot. This is one way to approach a full-sized debate step by step:

- 1 vs 1: Individuals give one three minute speech and 2-minute rebuttal
- 2 vs 2: Two 3-minute speeches vs 2 2-minute rebuttal speeches
- 3 vs 3: 3 4-minute speeches vs 2 2-minute speeches

Don't worry about reply speeches just yet (see next chapter 2.5). At this stage it is more important to understand and use the logic of designing and analysing arguments and refutation.

Coaches could give a first shot at judging as well (Appendix: Mark sheet (xiv)).

→ Appendix: Useful phrases for debaters (xi)

## 2.6 Creating reply speeches

Albert Einstein once said: "If you can't explain it simply, you don't understand it well enough". It may be helpful to always keep that in mind as a reply speaker.

A reply speaker's task is to give a 4-minute persuasion of the audience and the judges about why the debate goes to his own team, and has to reduce it to the three or maybe four most important *clashes* or *areas of contention* it featured and must explain from his point of view why his team wins each and every one of them through reasoning and emphasising the principle concepts about why their own arguments outweigh the others'. The more a debater engages in dealing with minor arguments and/or individual examples, or even adds new examples, the more he may not have understood the general principle of his own team's line of argumentation.

Basically, it is about coming back to the case and the general ideas or demands of each team, which are of course competing. The reply speakers should not deal with individual arguments or examples again. Rather, they outline the main fields where side PROP and OPP disagreed (or clashed) and tell the audience and judges once again why they should side with the respective team.

So if, say, the motion was again about the ban of smoking in public places, there are two very general ideas clashing. PROP focuses on health issues and the protection of the weakest members of society (e.g. children) while side OPP will stress the notion of civil liberties, the value of self-determination and individuality. As you can see, a reply speaker will not deal with a minor example ("Side PROP mentioned kindergartens as public places where children are potentially exposed to smoking, but we disagree because..."), but with the broad picture.

Throughout the debate, the three major clashes might have been (1) responsibility for the protection of children vs. civil liberties (2) Health (People would still be allowed to smoke at home, why would they then be healthier only because they can't smoke in public places)? (3) Feasibility (is side PROP's plan really going to achieve anything? Children would still be exposed to smoking in private places, who would control this ban?)

As already said in 1.5.7, the speaker must take a step back and look at the big picture of what has been said from a bird's-eye point of view. Most speakers come up with analogies to exemplify what the flaws in the opposing team's argumentations were, like a house on solid pillars and a house which has crumbled under the overpowering weight of one's own team's arguments.

Reply speeches should not feature new material, let alone new arguments, but simply point out strengths of their own and weaknesses in the opposing team's case.

→ Appendix: Useful phrases for debaters (xi)

## 3 Debating in the classroom

The one great advantage to classroom debating over an isolated club is that the students can't stay away from it. In the classroom you are boss and say what's done and what isn't. If you believe that debating should be part of your English lessons as well, then this chapter will hopefully give you enough material to make it happen effectively.

Please note that the WSDC format is very difficult to fully implement into classroom situations. The debates themselves take more than one full hour and it only includes six speakers. The other members of the class would just sit there doing nothing but listening. There could be a discussion right afterwards, but it would generally see six speakers doing a lot of work and preparations and the rest of the class would need to be occupied with something other than debating.

One can, however, use elements of WSDC, but would have to make it so that everyone is included. The following two chapters will show you a possible approach on how to do that.

### 3.1 Debate topic selection

Unless there are any local topics or favourites from the class you'd like to discuss, debating may be a nice wrap-up of a unit you have just conducted.

Let's say you have just finished a unit on the British Empire. One could discuss whether not everything has been entirely bad or entirely good, for example:

- THBT the British empire has done more harm than good
- THBT the British Empire has brought prosperity to its colonies
- THBT the British Empire was a success

One could also find discussion topics about literary characters and their relationships to each other.

- THBT <char A> is racist / a hypocrite / a coward
- THBT imperial officers mustn't have intimate contacts with natives

You can introduce the motion in the THBT manner or simply write it as a question:

- Has the British Empire done more harm than good?

Side PROP would therefore answer this question with 'yes', whereas side OPP would negate it.

### 3.2 45-minute lessons

Surely, preparing and conducting a debate within 45 minutes is impossible. What you can do, however, is to have one lesson of preparations and one lesson with one debate with just 5-minute speeches without reply speeches (30 mins + feedback).

You can also spend time doing debating games and exercises, as explained in section 2.3. Depending on which topic you have just dealt with in class, you may also want to use topics in connection with it when playing games. Simply replace the topic examples from 2.3 with any other topic you find suitable for debate.

### 3.2.1 Group activities

In larger groups, it is difficult to entertain all participants. However, most of the games described in 2.3 can be played with big groups just by splitting them up into two or three larger groups that work independently from each other. These are:

- If I ruled the world (2.3.1.1)
- Alley Debate (2.3.1.2)
- The Why Game (2.3.1.3) - one person in front of the whole group
- Criminal Past (2.3.4.1)
- Phone Terror (2.3.4.2)
- Mad discussion (2.3.4.4)

On top of these, there is a game called *For or Against*, which takes a die for each group of three students. In the given example, there are questions raised from the topic of 'New Media'.

- 3 players per team
- One photocopy of the discussion topics per team.
- You will need as many dice as there are teams.
- The rolled die decides on the debate topic box.
- The number rolled is the number of the line from which you get your topic. Students go from left to right.
- The player must speak for two minutes, using the ARE/SEE model:
  - Argument
  - Reason why it is important
  - Example(s)
- To avoid repetition, every topic must be used only once.
- Play as long as it takes to deal with all topics or as long as time allows or until each team has spoken for 15 minutes cumulatively.

→ Teaching Sheet 6: 'New Media' discussion topics (ix)

### 3.2.2 Group debates

In an example group size of 30, the class can be split up into two groups of 15, which then can be divided into two groups of seven and eight. The goal is to have these two groups have one open discussion each.

Give the students two debate topics, either from the collection in the back or one that suits the needs of the unit better.

#### 1<sup>st</sup> lesson:

- Students are split up into groups and are given the topics.
- Students choose the side they want to be on (or you assign them via role cards)
- Introduce them to SPERM, ARE/SEE models and Four-step refutation (2.3.5, 2.3.6, 2.4.2)
- Students brainstorm ideas of what they want to say

#### 2<sup>nd</sup> lesson:

- If available, students should be allowed to now use the internet as a resource, especially for examples
- Students should write key information onto palm cards

### 3<sup>rd</sup> lesson:

- 1<sup>st</sup> debate of group A takes place
- Say a few words to open the debate or choose one or two students from the other group as moderators
- Allow 15' of speaking time
- the rest of the lesson should be an open discussion with the whole group

### 4<sup>th</sup> lesson:

- 2<sup>nd</sup> debate of group B takes place
- Say a few words to open the debate or choose one or two students from the other group as moderators
- Allow 15' of speaking time
- the rest of the lesson should be an open discussion with the whole group

If you have 90-minute lessons available you can simply use the first session for research and the second for the debates.

## 3.3 90-minute lessons

A second variation from the 45-minute lessons could cover four sessions and lead to three quasi-WSDC debates and open discussions. Whereas this reduces the speaking performance to just three people per side, having three debates already activates 18 people as speakers. The remaining students not speaking in the debate will be able to participate in the preparations.

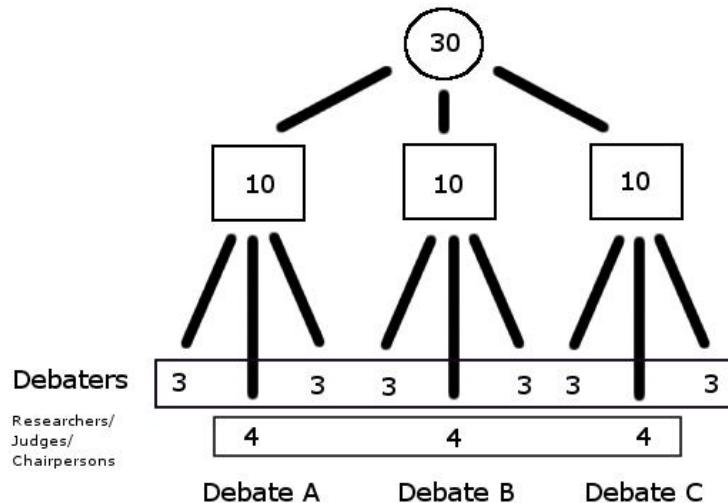

*Fig. 7: Division of class members*

Three groups of ten people work on one motion each (see Appendix: Motions (xii)). People who are not debating will assist in the preparations and can work as judges of the other debates or as chairperson and timekeeper (see 1.4). Speaking time should be no longer than 5 minutes per person to allow for group discussions with the whole class after each debate. The goal is to reach every class member to take active part in the discussion.

For timing reasons you should ignore reply speeches. You may add them, of course if you so wish.

A possible syllabus for four or five sessions could look like this:

Possible 1<sup>st</sup> lesson:

- If you have time to spare, show your students the model debate from 1.6 (62')

1<sup>st</sup> lesson:

- Create teams, hand out Teaching Sheets 7 and 8 and Appendix: "Useful Phrases for Debaters" (xi)
- You can either have the students pick their roles or hand out role cards (Teaching Sheet 9)
- Familiarise your students with POIs (1.3.3)
- Conduct research

2<sup>nd</sup> lesson:

- Conduct research
- Prepare speeches, according to Teaching Sheet 7

3<sup>rd</sup> lesson:

- Debates 1 & 2 take place (Speaking time per speaker: 5')
- Use Teaching Sheet 8 for judges
- Add group discussion after each debate

4<sup>th</sup> lesson:

- Debate 3 (Speaking time per speaker: 5')
- Use Teaching Sheet 8 for judges
- Add group discussion after Debate 3
- → Final feedback through fellow students and teacher

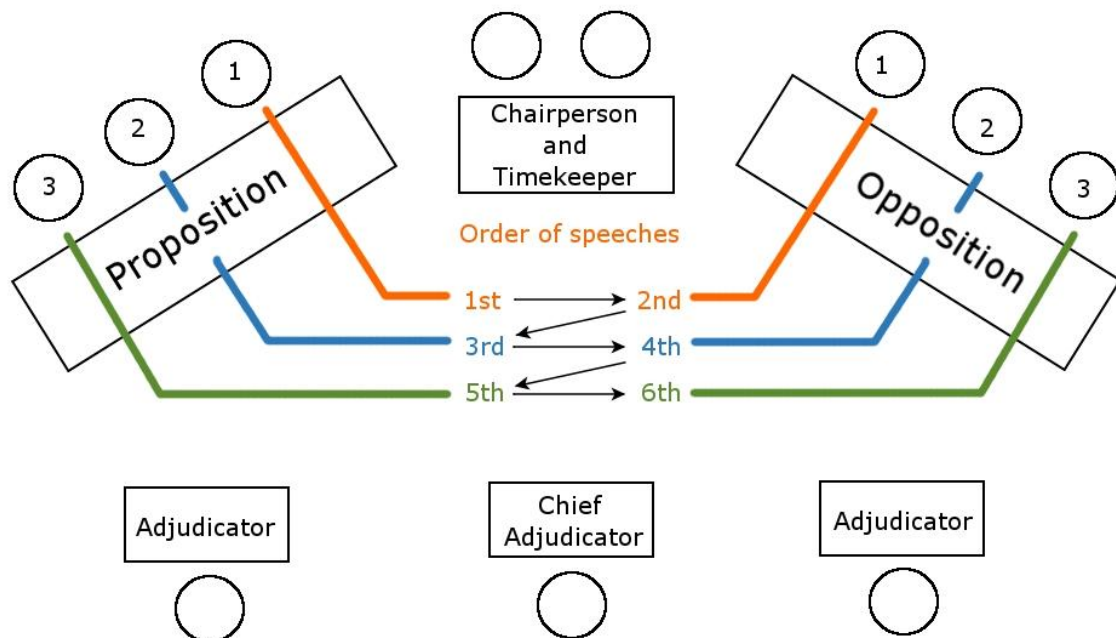

*Fig. 8: Debate layout (Speaking time: 5 minutes, no reply speeches)*



## 4 Debating tournaments in Germany

### 4.1 DSG Junior League (JL)

DSG Junior League was first introduced in the school year 2003/2004 as a preparatory tournament to motivate younger debaters into speaking in a competition. It comprises school years 8 and 9 and is typically conducted from JAN-MAY in every school year.

JL is currently divided into regional districts Baden-Württemberg and Saxony. Both regions meet once a year at the youth hostel in Würzburg, Bavaria to determine a national winner. If you want to create a new region or contact the nearest school that has JL debating, please send an e-mail to:

 [jlnational@schoolsdebate.de](mailto:jlnational@schoolsdebate.de)

Contact JL Saxony:

 [saxony@schoolsdebate.de](mailto:saxony@schoolsdebate.de)

Contact JL Baden-Württemberg:

 [bawue@schoolsdebate.de](mailto:bawue@schoolsdebate.de)

Find the most current JL updates here:

 [DSG Junior League](#)



Pics. 12-17: Impressions from JL National Final Weekend, Würzburg, 2011/12



Pic. 18: JL Winners 2010/11 from Schubart-GYM, Ulm

## 4.2 DSG Senior League (SL)

DSG Senior League is comprised of teams from school years 10 or higher and is with almost 50 teams the currently largest DSG tournament. SL regions are divided into SL South (Hessen, Baden-Württemberg, Bavaria), SL Berlin, SL Hamburg and SL Saxony, but any schools from outside these states can participate as well.

There is currently no national meeting, since it is increasingly difficult to find meeting weekends without conflicting with any of the participating regions' holiday schedule. However, DSG is organising the German Schools Debating Championship (GSDC) around Ascension Day weekend annually to compensate for this missing national league title (see 5.3).

The typical schedule, for example in SL South, begins with two Saturday meetings (four rounds altogether) between October and Christmas. In February, SL South teams meet in the Würzburg Youth Hostel for two nights to debate the remaining four preliminary rounds, adding up to eight altogether.

Teams breaking into the final rounds (currently the best eight) will be invited again for two meetings of quarterfinals, semifinals and one Grand Final.

For more SL info outside South, Berlin, Hamburg and Saxony please contact:

[slnational@schoolsdebate.de](mailto:slnational@schoolsdebate.de)

Contact SL Berlin:

[berlin@schoolsdebate.de](mailto:berlin@schoolsdebate.de)

Contact SL Saxony:

[saxony@schoolsdebate.de](mailto:saxony@schoolsdebate.de)

Contact SL South:

[slsouth@schoolsdebate.de](mailto:slsouth@schoolsdebate.de)

Contact SL Hamburg:

[hamburg@schoolsdebate.de](mailto:hamburg@schoolsdebate.de)

Find the most current SL updates here:

[DSG Senior League](#)



Pics. 19-23: Impressions from DSG Senior League 2011/12

## 4.3 German Schools Debating Championship (GSDC)

The GSDC is an annual four-day event around Ascension Day weekend. It takes place in shifting locations, mainly Stuttgart, Berlin and in the future possibly Dresden, representing the largest regions currently active in debating: Southwest, Berlin and Saxony.

All German schools debating teams, regardless of the participants' age, are invited to spend four days of debating with fellow school teams, including seven preliminary rounds, a quarterfinal, a semifinal and a tournament Grand Final (see pictures on page 12).

## 4.4 EurOpen

EurOpen is the only international tournament offered by DSG annually. It has been taking place in Stuttgart ever since 2001. Countries from all over the world meet to debate against local and other German school teams. Countries that have been represented at EurOpen in previous tournaments include:

Czech Republic

- Slovenia
- Slovakia
- Turkey
- Canada
- South Korea
- South Africa
- Netherlands
- Romania
- Belarus
- Israel
- Montenegro
- Serbia
- Greece
- Hungary
- Croatia
- Russia
- Ukraine
- Finland
- Nigeria
- Denmark
- England
- Qatar
- USA
- Pakistan
- China



Pics.24-29: Impressions from EurOpen, Stuttgart

Find the most current EurOpen updates here:

<http://www.europen-debate.net>

## 4.5 University Debating

If your students are close to graduation, then becoming a university debater can be quite an interesting career option to increase their presentation and speaker abilities, along with broadening their general knowledge preparing for a large and growing number of IVs (Intervarsity tournaments) at German universities, as well as universities around the world.

EUDC (European University Debating Championship) and WUDC (World University Debating Championship) are the two largest tournaments from the European point of view and are very worth attending.

Get more info about university debating at the VDCH - *Verband der Debattierclubs an Hochschulen*

## 5. Debating tournaments abroad

DSG has gathered many contacts in Europe and the world to send German national or school delegations to numerous events abroad. Regardless of the experience of your debaters, you can keep an eye on our webpage for calls for debaters, coaches and judges to be part of a delegation to either of the events.

Don't hesitate to send inexperienced speakers as well. They will find more teams at the same experience level anywhere they go.

The most frequented tournaments by DSG are:

- Heart of Europe, Olomouc, Czech Republic
- EurAsians, Istanbul, Turkey
- Slovenian Debating Weekend, Ljutomer, Slovenia
- World Schools Debate Academy, Kranjska Gora, Slovenia
- Middle School debate tournament (for Juniors), Slovenia
- Slovakian Open debating championship, Bratislava, Slovakia
- Zagreb Open SDC, Croatia
- Prague Debate Spring, Prague, Czech Republic
  
- World Schools Debating Championship (shifting locations)
- IDEA Youth Forum (KP format, shifting locations)

Visit our event calendar to find out about current events abroad and in Germany:

DSG event calendar



[http://www.schoolsdebate.org/index.php?option=com\\_jevents&Itemid=578&task=cat.listevents&language=en](http://www.schoolsdebate.org/index.php?option=com_jevents&Itemid=578&task=cat.listevents&language=en)

Apart from these tournaments, there are many more invitations, for example from Romania, Croatia, Ukraine and Montenegro that we couldn't take in the past since there are simply too few debaters who are actually available during school times.

At some tournaments abroad, you may be facing the condition of *power pairing*, which means, that the sides will be drawn instances before the round starts and then face teams matching team performance levels. In consequence this means that you will have to prepare both sides of the debate in preparation for the tournament. Once the side has been drawn, you need to grab your preparation work for the debate side drawn for you and enter the debate room, but do not toss the other side's preparations into the bin! You may still need them for preparing future events that have similar topics you will be debating over.

Please note that you mustn't use handwritten materials in impromptu debate preparations! Some students have sizeable diaries featuring pre-prepared materials that mustn't be used during preparation time.

## Teaching sheets / Appendix (i-xvii)

### Index

- Teaching Sheets
  - 1 What is a debate? (i)
  - 2 How to prepare speaking in front of an audience (ii)
  - 3 First speeches (iii)
  - 4 Public speaking feedback form (iv)
  - 5 Practice debate (BEG/JUN) (v)
  - 6 Fast four-step refutation practice (vi)
  - 7 'New Media' discussion topics (vii)
  - 8 Preparing a speech for classroom debate (viii)
  - 9 Judging a classroom debate (ix)
  - 10 Role cards for classroom debate (x)
- Useful phrases for debaters (xi)
- Motions (xii)
- Chairperson's speech (xiii)
- Mark sheet (xiv)
- Range of marks (xv)
- Time Cards to show to speaker as assistance (xvi - xvii)



# What is a debate?

- It is a fair discussion
- Has a topic that may be important for you (a *motion*)
- Communication event: be listened to, but also listen to others
- Two teams opposing
- Maximum of eight *speeches* per debate
- Points of Information (POIs) can be offered

Layout of a debate

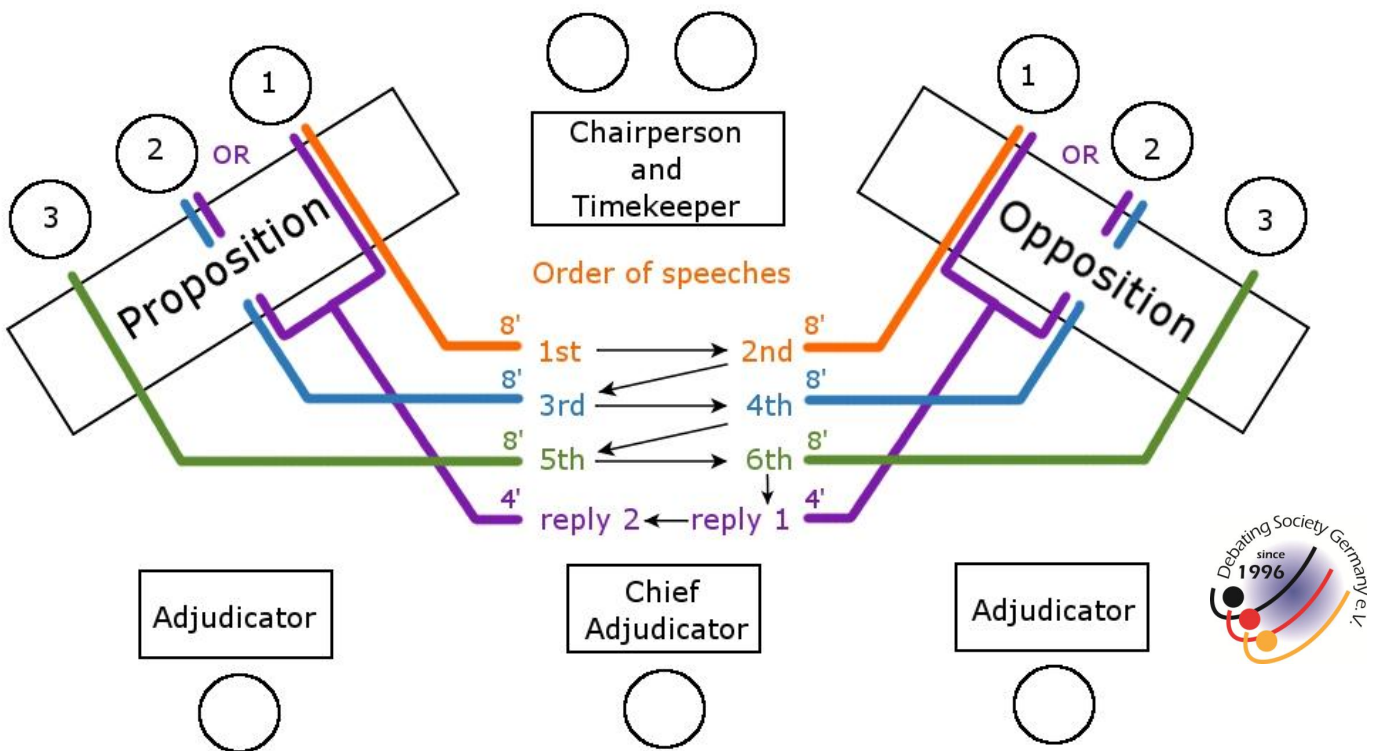



## Teaching sheet 2

### How to prepare speaking in front of an audience

It's okay to be a bit scared! Speaking in front of others makes everybody nervous 😊.  
But when you get more self-confident, it can be quite fun!

1. You need to do preparation for your debate side
  - First you need to know why your side of the debate has to win! What can you say that makes others believe you? You need to have *arguments*.
  - Get enough info about your motion to have material to talk about
    - from your head (what do you know already?)
    - from the internet
    - from newspapers
    - from magazines
    - from anywhere you want
  - Which argument do you think is most important? Use that first!
    - WHY is it so important?
    - Can you prove why?
      - find examples
2. Write palm cards that help you
  - Put the argument at the top
  - Write down the examples/evidence in keywords
  - Write down vocabulary that is new to you
  - Write down vocabulary that is difficult
  - Write down very important sentences that are difficult for you

→ But don't write full texts, you need to be flexible if things don't go as planned!
3. Order your file cards by numbers
  - Don't mix them up, or your speech gets stuck
  - Use different colours for each of your arguments (markers)
4. Find linking words to connect your arguments (→ "Useful vocabulary")
5. Find phrases you want to use at the beginning and at the end (→ "Useful vocabulary")
6. Give your speech
  - Try and use short sentences at first
  - Don't repeat words too often
  - Use your palm cards, but don't forget eye contact
  - Try and speak as freely as you can (using words in your head, not on your palm cards)
7. Get feedback from your coach and co-debaters and give the same speech more often. Try and make it longer each time.
8. Also ask yourself: "What can I do better?" 😊



Teaching sheet 3  
First speeches

Topic cards to be handed out first (or projected onto the wall).  
You can choose other topics, if you like.

Why video games are cool	Why video games are bad	The joys of sports
A job I'd like to have	Where I would like to live	The Olympic Games
Airplanes	Cars	Friends
School	The future	My favourite country
Celebrities	Why cats are better than dogs	Why dogs are better than cats
Homework	The internet	Films in the cinema

Use the following phrases.  
There are more on your "Useful phrases for debaters" sheet.

*Hello! Today I am going to talk to you about....*

*I've divided my speech into.... main points:*

*First I am going to talk about....*

*My second(and last) point is...*

*My third (and last) point is about...*

*Let me now come to my first point ....*

*Now to my second point....*

*Finally, I'd like to talk about my third point...*

*So, what did I tell you today? I've told you that ..... and.... and....*

*Thank you for listening!*



Teaching sheet 4  
Public speaking feedback form

Name of debater: \_\_\_\_\_

<b>USE OF VOICE</b>  Speed:  Volume:  Modulation:	<b>FACE</b>  Eye contact:  Expression:
<b>HAND GESTURES</b>  too steady    too hectic  appropriate    distracting	<b>BODY MOVEMENT</b>  appropriate    distracting
<b>OTHER ASPECTS</b>	



Teaching sheet 5  
Practice debate (BEG/JUN)

Motions for practice debates

<b>THW ban zoos</b>	<b>THBT public transport should be free of charge</b>	<b>THW ban beauty contests</b>
<b>THW make fast food more expensive</b>	<b>THW shut down social networks</b>	<b>THW introduce school uniforms</b>
<b>THW ban video game consoles</b>	<b>THBT the internet is the better teacher</b>	<b>THBT pupils should pay money for not doing homework</b>
<b>THW ban pets</b>	<b>THBT there should be more discipline in schools</b>	<b>THBT there should be less reading and more watching films in schools</b>
<b>THBT kids should be forced to read books</b>	<b>THW ban talk shows</b>	<b>THBT every pupil must learn a musical instrument in school</b>

Side cards to draw speakers to PROP or OPP

<b>PROPOSITION 1st speaker</b>	<b>PROPOSITION 1st speaker</b>	<b>OPPOSITION 1st speaker</b>	<b>OPPOSITION 1st speaker</b>
<b>PROPOSITION 2nd speaker</b>	<b>PROPOSITION 2nd speaker</b>	<b>OPPOSITION 2nd speaker</b>	<b>OPPOSITION 2nd speaker</b>
<b>PROPOSITION 3rd speaker</b>	<b>PROPOSITION 3rd speaker</b>	<b>OPPOSITION 3rd speaker</b>	<b>OPPOSITION 3rd speaker</b>

Please note:

After some rounds of debates, pupils may find a favourite speaker position they feel most comfortable with. Most flexible speakers feel secure in all three positions, but are rare. Debaters need to be aware that sometimes they may have to debate a position they don't feel comfortable with.



Teaching sheet 6

Fast four-step refutation practice

1. Every debater receives a slip with an argument.
2. The first debater has 30 seconds to prepare a refutation of that argument.
3. Read out the argument and give your refutation.
4. While the first debater is speaking, the next in line receives his argument and prepares his refutation.
5. Continue until all debaters have refuted one argument.
6. Do all rounds again one more time and repeat the same refutation. Try and speak longer this time.

**Angela Merkel is from East Germany and therefore unfit to govern all of Germany.**

**If the US economy is not doing well, Barack Obama is the only one to blame.**

**If immigrant families are not happy in their host country, they should go back to where they come from.**

**Economic experts say that the economic situation will improve next year. They must be right.**

**McDonald's is the most popular restaurant in the world. It must be the best food.**

**The only way to improve the educational system is to spend more money on it.**

**North and South Korea should reunify. It worked for Germany.**

**The EU is the world's best democracy, so others should copy the EU's form of government.**

**Mister Y, the baseball star, says, "Smokies are the least harmful of all cigarettes."**

**Freedom of speech is more important than security from terrorism.**

**Public nudity at beaches is obscene and dangerous**

**All over the world we must guarantee equal rights for women.**

**Economic growth should always be pursued as a goal.**

**Freedom of the press is more important than the privacy of government officials.**

Teaching sheet 7

'New Media' discussion topics

1. Get into groups of three.
2. First player rolls the die.
3. The number you've rolled indicates the box from which to get your topic from. Go from left to right.
4. Roll the die a second time. If you have a 1-3, you must support the question (YES). If the die shows 4-6, you must be against the topic (NO).
5. You have one minute to prepare your speech.
6. Speak about your topic, giving an argument, a reason why you chose this argument, as well as examples.
7. Another team member takes the time (watch, stopwatch).
8. Cross out the topic you've just talked about. It can't be used again.
9. Next player rolls the die. The game ends once the group has spoken for **15 minutes in total**.

●			
Should you only be allowed to be online with your <u>real</u> name?	Is the internet the better teacher?	Should violent computer games be banned?	Should social media websites be closed?
1-3 YES 4-6 NO	1-3 YES 4-6 NO	1-3 YES 4-6 NO	1-3 YES 4-6 NO

● ●			
Should music and film downloads be for free?	Should mobile phones be allowed in school?	Are newspapers not important anymore?	Should every pupil receive a tablet PC from the school?
1-3 YES 4-6 NO	1-3 YES 4-6 NO	1-3 YES 4-6 NO	1-3 YES 4-6 NO

● ● ●			
Can teenagers 'survive' without a mobile phone?	Should the internet be used instead of schoolbooks?	Are films more important than books?	Is time spent online a waste of time?
1-3 YES 4-6 NO	1-3 YES 4-6 NO	1-3 YES 4-6 NO	1-3 YES 4-6 NO

● ● ● ●			
Do computer games make kids stupid?	Should there be censorship of the internet?	Should every child have a Facebook account?	Should the school stop teaching art?
1-3 YES 4-6 NO	1-3 YES 4-6 NO	1-3 YES 4-6 NO	1-3 YES 4-6 NO

● ● ● ● ●			
Should every child have its own mobile phone?	Does the internet bring more harm than good?	Should the school stop teaching music?	Is TV still important?
1-3 YES 4-6 NO	1-3 YES 4-6 NO	1-3 YES 4-6 NO	1-3 YES 4-6 NO

● ● ● ● ● ●			
Are dating websites a good idea?	Should the internet be forbidden as a source for school presentations?	Should there be internet lessons in school?	Should there be an internet PC in every classroom?
1-3 YES 4-6 NO	1-3 YES 4-6 NO	1-3 YES 4-6 NO	1-3 YES 4-6 NO

Teaching sheet 8

Preparing a speech for classroom debates

1. You will need three speakers to defend your side (PROP or OPP).
2. Find three arguments. Let Speaker 1 deal with two and Speaker 2 with one of them.
3. Give a reason why you chose every argument and find examples to back them up.
4. Speaking time is 5 minutes.
5. Except for PROP Speaker 1, it will be expected from you to rebut the arguments of the other side (why are they wrong?).
6. Offer Points of Information (POIs)

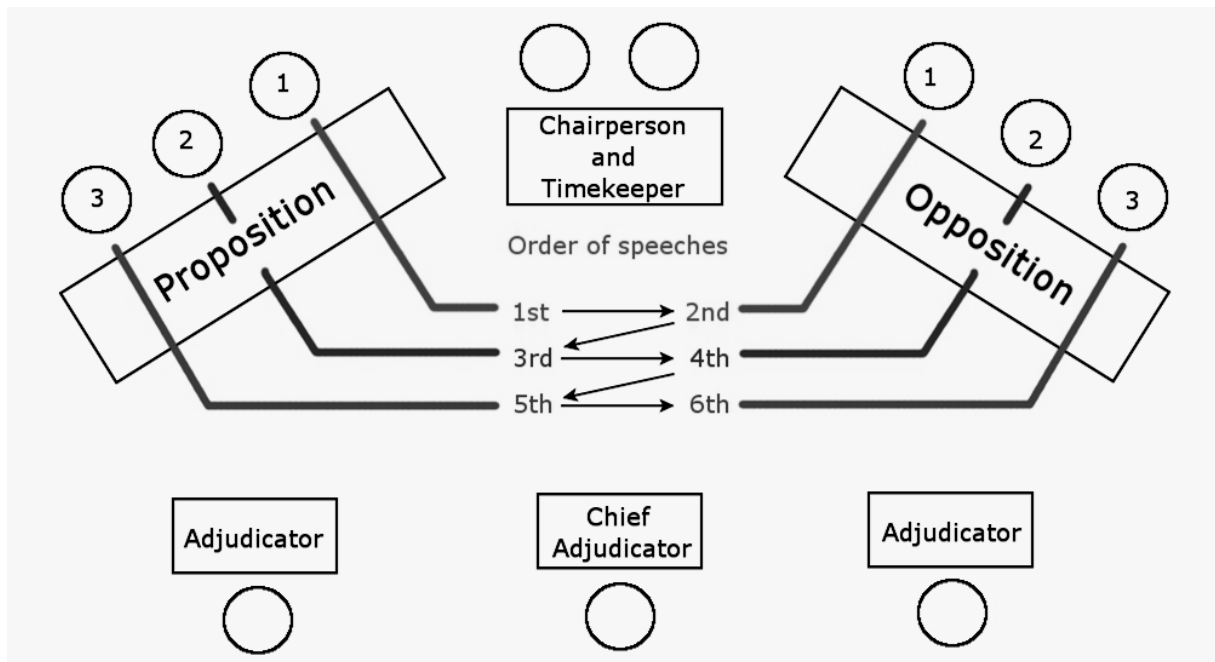

Use the following phrases.  
There are more on the "Useful phrases for debaters" sheet.

*Hello! Today I am going to talk to you about.....*

*I've divided my speech into.... main points:*

*First I am going to talk about....*

*My second(and last) point is...*

*My third (and last) point is about...*

*Let me now come to my first point ....*

*Now to my second point....*

*Finally, I'd like to talk about my third point...*

*So, what did I tell you today? I've told you that ..... and.... and....*

*Thank you for listening!*



Teaching sheet 9  
Judging classroom debates

**Arguments**

plausible \_\_\_\_\_ implausible

**Argument arrangement**

logical \_\_\_\_\_ illogical

**Dealing with opponent (incl. POIs)**

engaging \_\_\_\_\_ passive

**Examples**

great \_\_\_\_\_ just right \_\_\_\_\_ close to none

**Style**

audible \_\_\_\_\_ too quiet

eye contact \_\_\_\_\_ passive

open \_\_\_\_\_ hidden

**Timing**

too short \_\_\_\_\_ just right \_\_\_\_\_ overtime

I award this debate to side (please circle)    PROP    OPP

Judge's name: \_\_\_\_\_



## Role cards for classroom debates (30 students)

<b>Debate A Proposition 1<sup>st</sup> Speaker</b>	<b>Debate B Proposition 1<sup>st</sup> Speaker</b>	<b>Debate C Proposition 1<sup>st</sup> Speaker</b>
<b>Debate A Proposition 2<sup>nd</sup> Speaker</b>	<b>Debate B Proposition 2<sup>nd</sup> Speaker</b>	<b>Debate C Proposition 2<sup>nd</sup> Speaker</b>
<b>Debate A Proposition 3<sup>rd</sup> Speaker</b>	<b>Debate B Proposition 3<sup>rd</sup> Speaker</b>	<b>Debate C Proposition 3<sup>rd</sup> Speaker</b>
<b>Debate A Opposition 1<sup>st</sup> Speaker</b>	<b>Debate B Opposition 1<sup>st</sup> Speaker</b>	<b>Debate C Opposition 1<sup>st</sup> Speaker</b>
<b>Debate A Opposition 2<sup>nd</sup> Speaker</b>	<b>Debate B Opposition 2<sup>nd</sup> Speaker</b>	<b>Debate C Opposition 2<sup>nd</sup> Speaker</b>
<b>Debate A Opposition 3<sup>rd</sup> Speaker</b>	<b>Debate B Opposition 3<sup>rd</sup> Speaker</b>	<b>Debate C Opposition 3<sup>rd</sup> Speaker</b>
<b>Debate A Researcher Chairperson Debate C</b>	<b>Debate B Researcher Chairperson Debate A</b>	<b>Debate C Researcher Chairperson Debate B</b>
<b>Debate A Researcher Judge Debate B</b>	<b>Debate B Researcher Judge Debate A</b>	<b>Debate C Researcher Judge Debate A</b>
<b>Debate A Researcher Judge Debate C</b>	<b>Debate B Researcher Judge Debate A</b>	<b>Debate C Researcher Judge Debate B</b>
<b>Debate A Researcher Judge Debate C</b>	<b>Debate B Researcher Judge Debate C</b>	<b>Debate C Researcher Judge Debate B</b>

## Useful phrases for debaters

<b>Opening a speech</b>	
Today I am going to talk to you about...	<i>Heute spreche ich über...</i>
First of all,...	<i>Zu allererst...</i>
To begin with,...	<i>Beginnen wir mit...</i>
<b>Linking points</b>	
Secondly,... / In the second place...	<i>Zweitens,...</i>
Moreover,...	<i>Darüber hinaus, ... / Zusätzlich...</i>
Besides,...	<i>Davon abgesehen,...</i>
Furthermore,...	<i>Weiterhin,... / Zusätzlich...</i>
The most important point, however, is...	<i>Der wichtigste Punkt, allerdings, ist...</i>
<b>Finishing</b>	
(But) above all,...	<i>(Aber) vor allen Dingen...</i>
Finally,... / Lastly,...	<i>Schließlich, endlich...</i>
In conclusion,...	<i>Daraus schließe ich</i>
To sum up,...	<i>Zusammenfassend...</i>
What have I told you so far?...	<i>Was habe ich Ihnen heute also erzählt?</i>
<b>Points of information</b>	
On that point, sir/madam.	<i>Zu diesem Punkt, mein Herr / meine Dame</i>
Point of information?	<i>Eine Anmerkung dazu?</i>
Please, go ahead. / Yes, please.	<i>Ja, bitte.</i>
No, (sorry) declined.	<i>Nein, abgelehnt.</i>
No, thank you.	<i>Nein, danke.</i>
I'll take you in a second/minute.	<i>Ich nehme Sie gleich dran.</i>
<b>Statements of a personal viewpoint</b>	
I firmly believe...	<i>Ich glaube fest daran, dass...</i>
Personally I think...	<i>Ich persönlich denke...</i>
As far as I'm concerned I think that	<i>Was mich betrifft, bin ich der Überzeugung, dass</i>
In my opinion...	<i>Meiner Meinung nach...</i>
<b>Statements of a general viewpoint</b>	
It has often been said that...	<i>Es wurde oft gesagt, dass...</i>
There are some who claim that...	<i>Es gibt einige, die behaupten, dass</i>
Many are convinced...	<i>Viele unterstützen die Ansicht, dass...</i>
The general opinion is that...	<i>Die gängige Meinung ist...</i>
<b>Rebuttal</b>	
The PROP/OPP has two main arguments, but...	<i>Die PROP/OPP brachte zwei Hauptargumente, aber</i>
The PROP/OPP failed to acknowledge the fact that...	<i>Die PROP/OPP erkannte die Tatsache nicht, dass...</i>
In spite of all your examples you've failed in convincing us...	<i>Trotz all ihrer Beispiele haben sie es versäumt, uns davon zu überzeugen, dass...</i>
The PROP/OPP wants to make us believe that...	<i>PROP/OPP möchte uns weiß machen, dass</i>
The PROP/OPP tried in vain to convince us that...	<i>PROP/OPP versuchte vergeblich uns davon zu überzeugen, dass...</i>



## Motions

### Beginners

- THBT public transport should be for free
- THBT there is too much advertising in sports
- THBT all pupils should wear school uniforms

### Juniors

- THBT advertising shouldn't aim at kids
- THW make teacher evaluation mandatory
- THB in patchwork families
- THW ban same-sex marriages
- THBT comprehensive schools are the solution
- THW ban private health insurance
- THBT the American government is a model for the world
- THW ban Carnival
- THB in patriotism
- THW limit immigration
- THW lower the voting age

### Seniors

- THBT gay couples should be allowed to adopt children
- TH disapproves of cloning
- THW legalise prostitution
- THBT cultural treasures belong at home
- THBT the welfare state should be scrapped
- THW negotiate with terrorists
- THW punish sports teams whose fans misbehave
- TH supports the international trading of pollution quotas
- THW limit media reporting of terrorist atrocities
- THBT we should support military intervention in Somalia
- THBT doctors should report evidence of marital abuse to the police
- THW not eat meat
- THW stop sending humans into space
- THBT autocracy is doomed in the age of Facebook
- THBT public services are best run by private companies
- THW ban strikes by those working in essential state services
- THW expand the permanent membership of the UN Security Council
- THBT governments should never bail out big companies
- TH supports missile defence
- THBT professionalism has ruined the Olympic Games
- TH supports quotas for women in national parliaments



## Chairperson's announcement speech

Ladies and gentlemen, welcome to this debate! May I remind you to switch off your mobile phones.

Thank you.

The motion for this round today is " \_\_\_\_\_ "

Debating this round are Team " \_\_\_\_\_ ", who are proposing, as well as Team " \_\_\_\_\_ ", who are opposing.

Speaking for the proposition are first speaker \_\_\_\_\_, second speaker \_\_\_\_\_ and third speaker \_\_\_\_\_.

Please welcome them!! <applause>

Speaking for the opposition are first speaker \_\_\_\_\_, second speaker \_\_\_\_\_ and third speaker \_\_\_\_\_.

Please welcome them!! <applause>

Judging this debate are

(name) \_\_\_\_\_ from (school/country) \_\_\_\_\_,

(name) \_\_\_\_\_ from (school/country) \_\_\_\_\_, and

(name) \_\_\_\_\_ from (school/country) \_\_\_\_\_.

Please welcome them!! <applause>

Speaking time for the speeches are \_\_\_\_ (6/8) minutes. The first and the last minutes are protected from points of information. A knock/ring will be sounded after the first and the \_\_\_\_ (fifth/seventh) minute. There are no points of information during the reply speeches.

It is now my pleasure to welcome (name) \_\_\_\_\_, the first speaker of the proposition to open the debate.

<After every speech>: Thank you, (name) \_\_\_\_\_, for your speech!

### <Next speeches (examples)>:

- I'd now like to call \_\_\_\_\_ to give his/her speech
- It is now my pleasure to ask \_\_\_\_\_ to give his/her speech.
- Please welcome \_\_\_\_\_, the (1st/2nd/3rd) speaker of the (prop/opp).

### <Reply speeches>:

1.) It's now my pleasure to ask \_\_\_\_\_ to give the OPPOSITION'S reply speech.

2.) It's now my pleasure to ask \_\_\_\_\_ to finish this debate and give the PROPOSITION'S reply speech.

### <After the last speech>:

Thank you very much for this debate! Please shake hands and await the judges' decision. Good-bye!



British Embassy  
Berlin

## MARKSHEET

Proposition Team:	
Opposition Team:	
Date:	Round:
Motion:	
Judge:	

### Proposition Team

Name of speaker	Style/40	Content/40	Strategy/20	POI Adj.	TOTAL/100
1.					
2.					
3.					
Name of reply speaker	Style/20	Content/20	Strategy/10		TOTAL/50
Proposition team total/350					

### Opposition Team

Name of speaker	Style/40	Content/40	Strategy/20	POI Adj.	TOTAL/100
1.					
2.					
3.					
Name of reply speaker	Style/20	Content/20	Strategy/10		TOTAL/50
Opposition team total/350					

Winner team:
Judge's signature:

## Range of marks

### 1. Substantive speeches (out of 100)

Standard	Style / 40	Content / 40	Strategy / 20	Overall / 100
Exceptional	32	32	16	80
Excellent	31	31	15-16	76-79
Extremely good	30	30	15	74-75
Very good	29	29	14-15	71-73
<b>Good</b>	<b>28</b>	<b>28</b>	<b>14</b>	<b>70</b>
Satisfactory	27	27	13-14	67-69
Competent	26	26	13	65-66
Pass	25	25	12-13	61-64
Improvement needed	24	24	12	60

half points may be given

### 2. Reply speeches (out of 50)

Standard	Style / 20	Content / 20	Strategy / 10	Overall / 50
Exceptional	16	16	8	40
Very good to excellent	15	15	7.5	36-39
<b>Good</b>	<b>14</b>	<b>14</b>	<b>7</b>	<b>35</b>
Pass to satisfactory	13	13	6.5	31-34
Improvement needed	12	12	6	30

half points may be given

#### How to add up overall points without a calculator:

Assuming that you evaluate a speech with "Good" as a standard mark, you can simply add or subtract points from Style (28), Content (28) and Strategy (14), equaling an overall score above or below (70).

We usually never exceed +5 /-5 per category. But this is to your discretion.

Counting the points added or taken off per category equal the total deviation from 70.

Example:

	Style	Content	Strategy	
Deviation > 28/14	+1.5		+0.5	total deviation from 70: +1.5-0.5+0.5= <b>+1.5</b> <b>=71.5</b>
points given	29.5	27.5	14.5	
Deviation < 28/14		-0.5		

This is just a piece of advice. You may use any strategy most familiar to you.

Thank You for judging!

©2012 Debating Society Germany e.V.

1

2

3

4

5

6

7

- 30 sec



<b>-15 sec</b>	<b>STOP</b>	<b>+15 sec</b>	<b>+30 sec</b>
----------------	-------------	----------------	----------------

Give these cards to a team member, or even a team member of the opposing team, to assist the speaker(s) visually with the timing while giving their speeches.